



Includes instructions for 7 1/2' W x 7 1/2' D, 7 1/2' W x 10' D

Before You Begin...

- **Consult your local authorities for any permits required to construct shed.**

Prior to the construction of your shed, check with the local building code official to review any required permits or building limitations.

- **A level and sturdy foundation is required before shed construction can begin.**

Foundation recommendations and options are available in this manual.

- **Read instructions thoroughly prior to assembly.**

This kit contains parts that can be damaged if assembled incorrectly or in the wrong sequence.

- **Please follow instructions.**

Suncast is not responsible for replacing parts lost or damaged due to incorrect assembly.

- **Check for all parts before you begin.**

Using the provided parts check list on page 3, verify that you have all the parts required to construct your shed model. **COMPLETE SITE PREPARATION AND FOUNDATION CONSTRUCTION BEFORE UNPACKING ALL PARTS.**

- **Assistance is required.**

Due to the size of the parts, at least two people are required to handle, fit and secure shed components.



CAUTION

- Shed not intended for use in extreme weather conditions.
- Shed not intended for storage of flammable or caustic chemicals.
- Store heavy items near the bottom of shed.
- Shed not intended for use by children.
- Do not stand, sit, or store items on storage shed roof.
- Treat carefully in extreme temperatures.
- Repair or replace broken parts immediately.
- Suncast is not responsible for damage caused by weather or misuse.
- At regular intervals inspect your shed to make sure that assembly integrity has been maintained.
- Periodically check that the location you have chosen to set your shed is still level.
- This kit contains parts with metal edges. Please be careful when handling.

Shed Safety and Care

- Wash shed with garden hose or mild detergent solution and soft cloth. Do not use a stiff brush or abrasive cleaner as that could damage shed.
- Hot items, such as recently used grills, blowtorches, etc., must not be stored in the shed.
- Heavy articles should not be leaned against the walls, as this may cause panel distortion and permanent damage.
- Keep roof clean of snow and leaves.

Tools Required:

- Flat blade screwdriver
- Adjustable wrench
- Level
- Phillips head screwdriver
- Ladder
- Light duty work gloves
- Small rubber mallet
- Eye protection

Assembly Day Tips:

- **Complete site preparation and foundation construction before unpacking parts and beginning assembly.**
- **Do not attempt to assemble on a day with strong winds.**
- **Do not attempt to assemble on days when temperature is below 32 degrees.**
- **Set aside appropriate amount of time to completely assemble shed.**
- **Complete site preparation and foundation before unpacking and assembling.**
- **Make sure you have assistance nearby to lift and secure parts in place.**
- **Wear light duty work gloves while assembling shed.**
- **If you have questions on assembly, please call 800-846-2345.**

NOTE: This product contains parts that are used in different orientations to construct the shed. Please take note of the orientation of the parts shown throughout this instruction manual. Failure to follow instructions could result in damage to parts. Suncoast is not responsible for replacing parts lost or damaged due to incorrect assembly.

STRONGLY RECOMMENDED: Before beginning assembly, familiarize yourself with the parts by comparing the parts you have with the part names and quantities listed below. Use the Part Recognition illustrations on pages 4, 5, and 6 to help identify parts. **If a part is missing or damaged, please make note of which part it is and call 800-846-2345 for assistance.**

Parts List			
Part Name	Part Letter	7 1/2' W x 7 1/2' D Qty	7 1/2' W x 10' D Qty
Front Panel	A-A	2	2
Floor Post Connector	B	18	24
Male Ridge End	C	1	1
Left Door	DL	1	1
Left Header Panel	EL	1	1
Right Header Panel	ER	1	1
Right Door	DR	1	1
Floor	F-A	6	8
Female Corner Post	G	4	4
Male Corner Post	H	4	4
Mid Roof	J-A	4	6
Female Ridge End	K	1	1
Right Hinge Post	L	1	1
Door Latch Housing	M	2	2
Door Latch Pin	N	2	2
Left Hinge Post	P	1	1
Back To Header Connector	R	4	4
Side Panel	S	9	11
Right Door Handle	T	1	1
Roof to Side Connector	U	6	8
Mid Ridge	V	2	3
Left Door Handle	W	1	1
Right Roof Corner	X-A	2	2
Header to Header Snap	Y	2	2
Roof to Beam Connector	Z	6	8
Hinge Pin	DD	2	2
Left Roof Corner	CC-A	2	2
Right Floor to Back Connector	NN-A	1	1
Left Floor to Back Connector	MM-A	1	1
Left Floor to Front Connector	JJ-A	1	1
Right Floor to Front Connector	KK-A	1	1
#8-10 x 3/4" Pan Head Screw		38	44
Hex Head Cap 1/4-20 x 1 1/2"		3	3
Hex Nut 1/4-20		3	3
Steel Side Panel Support		6	8
Header Support Tube		2	2
Header Support Tube Bracket		2	2
Steel Ridge Beam		3	3
Cable Tie		10	10

Small Part Recognition

Using the illustrations, familiarize yourself with the parts required to construct your shed model. Parts shown are not to scale.

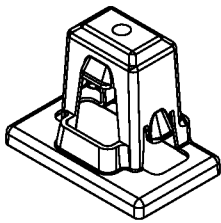

010160918
B
Floor Post Connector

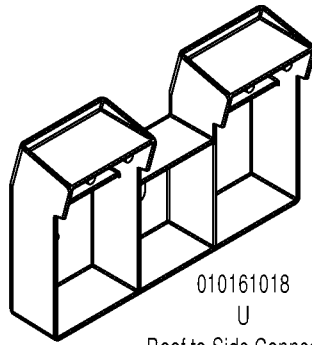

010161018
U
Roof to Side Connector

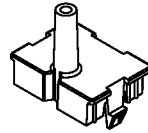

010161192
DD
Hinge Pin

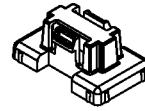

010157792
Y
Header to Header Snap

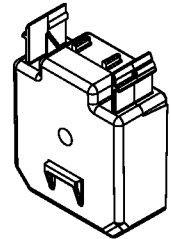

010161318
R
Back to Header Connector

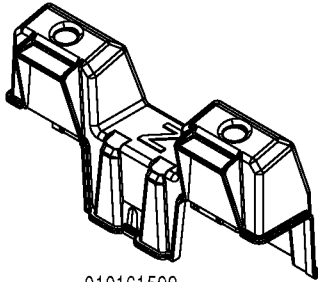

010161592
Z
Roof to Beam Connector

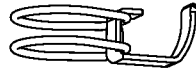

0280262
Header Support Tube Bracket

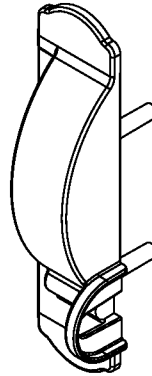

010161292
W
Left Door Handle



010162192
T
Right Door Handle



0430034
Cable Tie

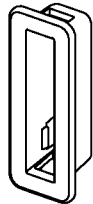

010122292
M
Door Latch Housing

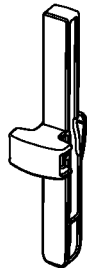

010122192
N
Door Latch Pin

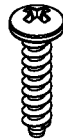

0210081
#8 - 10 x 3/4"
Pan Head Screw



0220012
1/4" - 20
Hex Nut

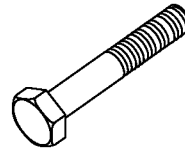

0210136
1/4" - 20 x 1 1/2"
Hex Head Cap Bolt



0280261
Header Support
Tube Bracket



0280274
Steel Side
Panel Support

Ridge Beam Recognition

Using the illustrations, familiarize yourself with the parts required to construct your shed model.

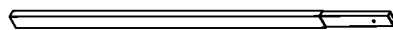

0440397 - 7 1/2 x 7 1/2 ft Beam Set

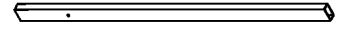

0440398 - 7 1/2 x 10 ft Beam Set

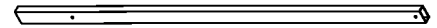
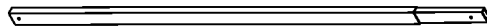

Large Part Recognition

Using the illustrations, familiarize yourself with the parts required to construct your shed model. Parts shown are not to scale.

NOTE: NOT ALL PARTS SHOWN ARE USED IN EVERY SHED MODEL.

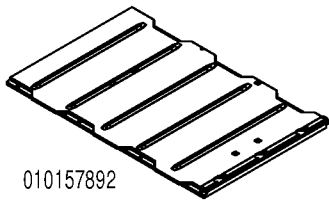

010157892
F-A
Floor Panel



010159518
JJ-A
Left Floor to Front Connector

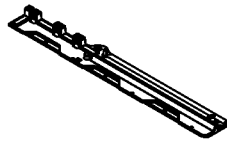

010159718
KK-A
Right Floor to Front Connector

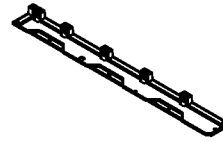

010159918
MM-A
Left Floor to Back Connector

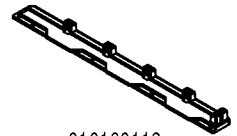

010160118
NN-A
Right Floor to Back Connector



010158518
H
Male
Corner
Post



010158618
G
Female
Corner
Post

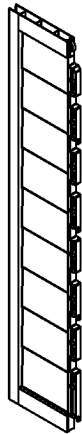

010158118
A-A
Front Panel



010159318
P
Left Hinge Post



010159418
L
Right Hinge Post

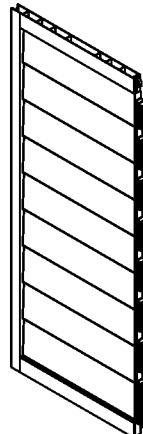

010158018
S
Side Panel



0462060
S
Side Panel with Window

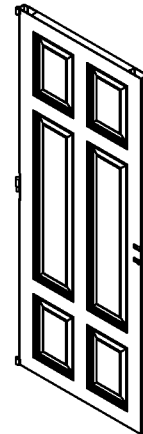

010158392
DL
Left Door

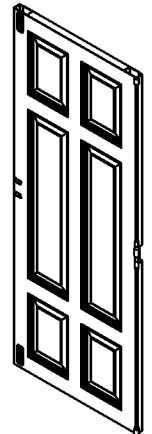

010158492
DR
Right Door

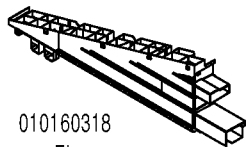

010160318
EL
Left Header Panel

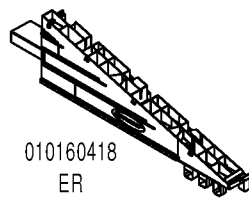

010160418
ER
Right Header Panel

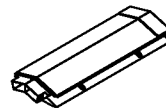

010160607
V
Mid Ridge

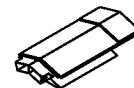

010160792
C
Male Ridge End

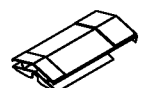

010160892
K
Female Ridge End

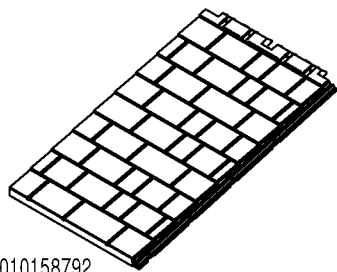

010158792
J-A
Mid Roof

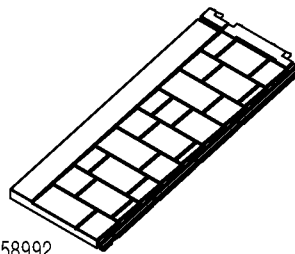

010158992
CC-A
Left Roof Corner

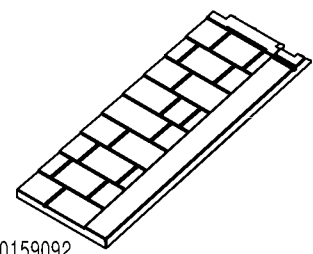

010159092
X-A
Right Roof Corner

Accessories Part Recognition

Using the illustrations, familiarize yourself with the parts required to construct your shed model. Parts shown are not to scale.

NOTE: NOT ALL PARTS SHOWN ARE USED IN EVERY SHED MODEL.

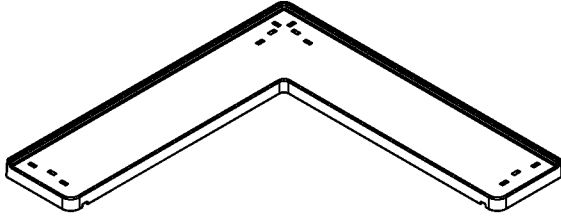

010161692
EE
Corner Shelf

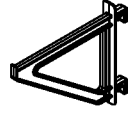

010161792
FF
Corner Shelf Bracket

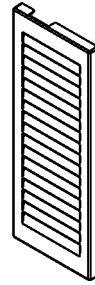

010162392
SSL
Left Shutter



010162492
SSR
Right Shutter

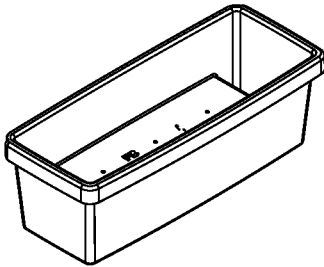

010162892
FB
Window Box

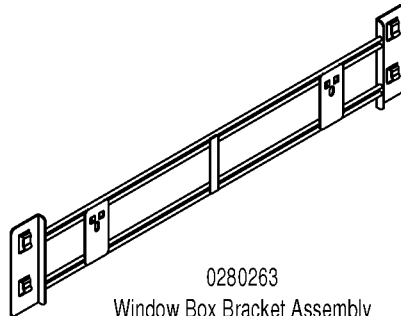

0280263
Window Box Bracket Assembly

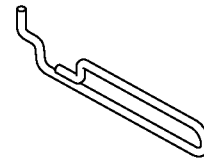

0280264
Window Box Support Hook

Floor Panel and Side Panel Layout

Using the illustrations, familiarize yourself with the parts required to construct your shed model.

SIDE PANELS WITH WINDOWS:

- If your shed model includes Side Panels with Windows, determine desired window location at this time.
- Side Panels with Windows may NOT be used as the panels on either side of the doors.
- If Shutters are used, Side Panels with Windows CANNOT be used in corner positions.

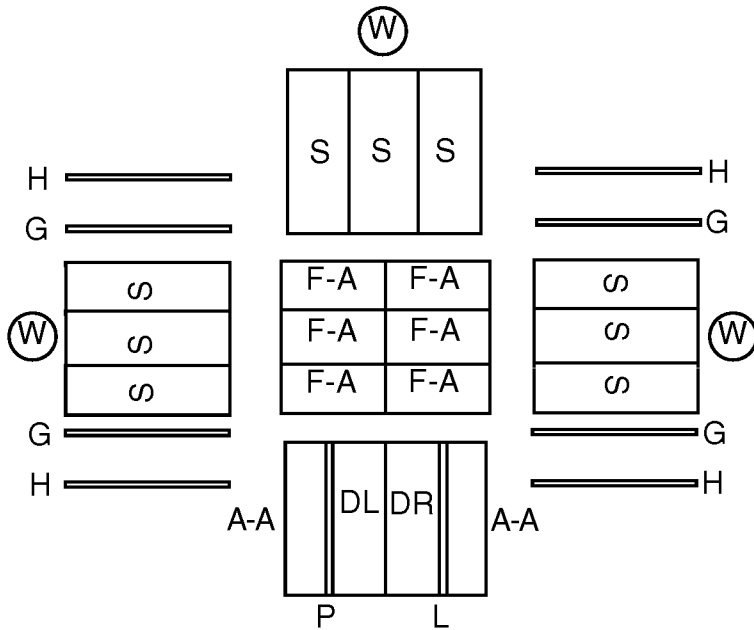

7 1/2' x 7 1/2'

W If your shed model includes the optional Side Panels with Windows, the circled W designates the recommended panel placement.

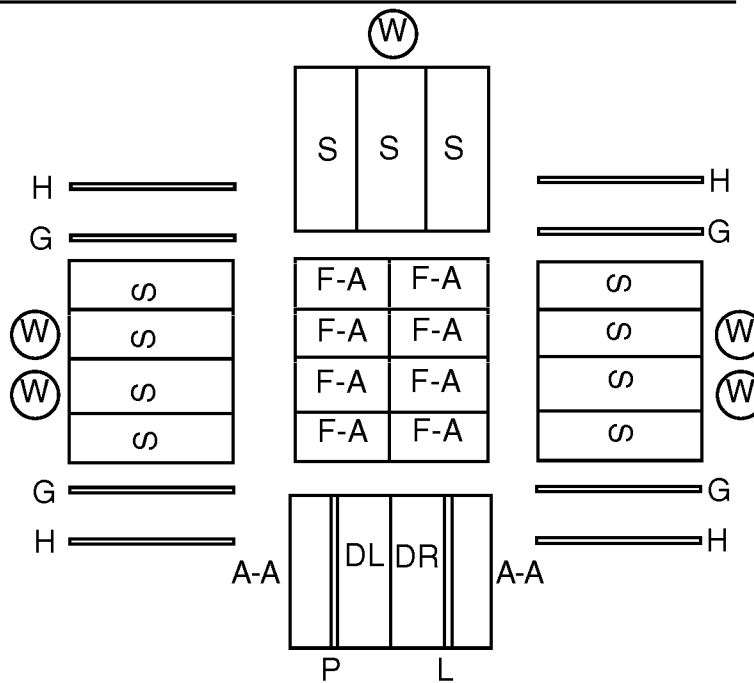

7 1/2' x 10'

Site Preparation and Foundation Construction (Materials not supplied with Shed Kit)

NOTE: Site preparation and foundation construction are required for this shed. Placing the shed on the ground without any type of foundation is not recommended. Without a foundation, settling will probably occur, causing distortion and damage to the shed. Suncoast is not responsible for replacing parts damaged or property lost due to incorrect assembly.

NOTE: Complete the site preparation and foundation construction before unpacking parts and beginning assembly.

To prepare your Shed site, follow the below steps:

1. Consult your local authorities for building codes and covenants before beginning foundation or erecting shed.
2. Before any digging, check with local utilities to determine location of buried cables, pipes, etc.
3. Decide which type of foundation you want:
 - Concrete slab, 4" thick **(Recommended)**
 - or
 - Wood platform

Use exterior grade wood. The wood platform should be set on pier blocks or footing. Consult your local retailer for help to determine the best anchoring method for your particular installation. The provided plans are sized for the minimum number of cuts to lumber and plywood. Your local retailer can cut the wood to size for you.
4. Prepare the building site:
 - The ground should slope away from the foundation area to provide drainage.
 - The foundation surface must be flat and level.
 - A vapor barrier should be provided to prevent excessive condensation in the shed.
 - Follow local building codes for a proper vapor barrier.
5. Anchoring the shed to the ground:
 - Consult your local retailer for help to determine the best anchoring method for your particular installation.
 - To secure the shed to a concrete pad, use masonry fasteners available at your local retailer.
 - To secure the shed to a wood platform, use 1/4" X 2" long lag screws with washers. See diagram on Page 13 for anchoring locations.

Concrete Slab Dimensions

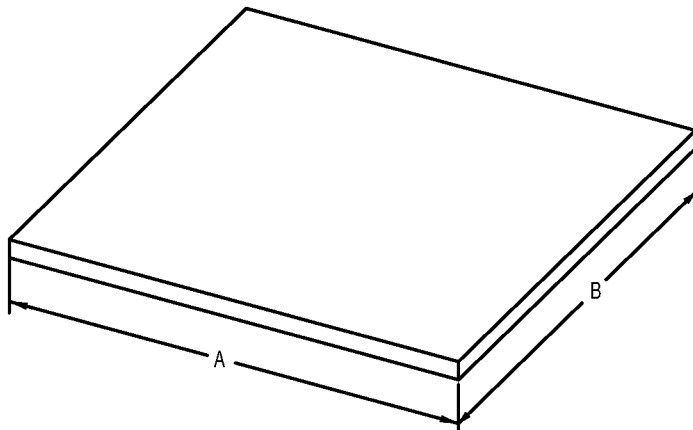

Concrete Slab - Suggested sizes

Shed Size	A*	B*
7 1/2' x 7 1/2'	8'-2"	8'-4"
7 1/2' x 10'	8'-2"	10'-8"

*Dimensions allow for approx. 3" extra on each side.

Wood Platform Dimensions

7 1/2' x 7 1/2'

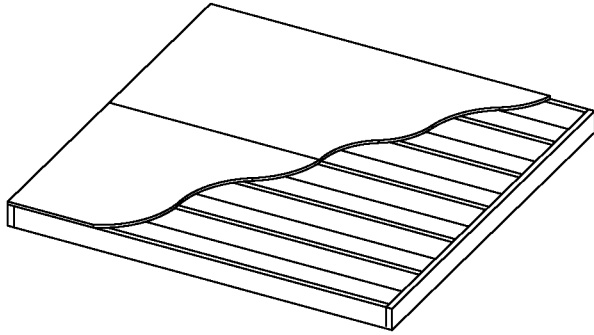

Materials List:

Item	Qty	Size
A	(7)	2" X 6" X 7'-9"
B	(2)	2" X 6" X 8'L
C	(2)	4' X 8' X 3/4" Plywood

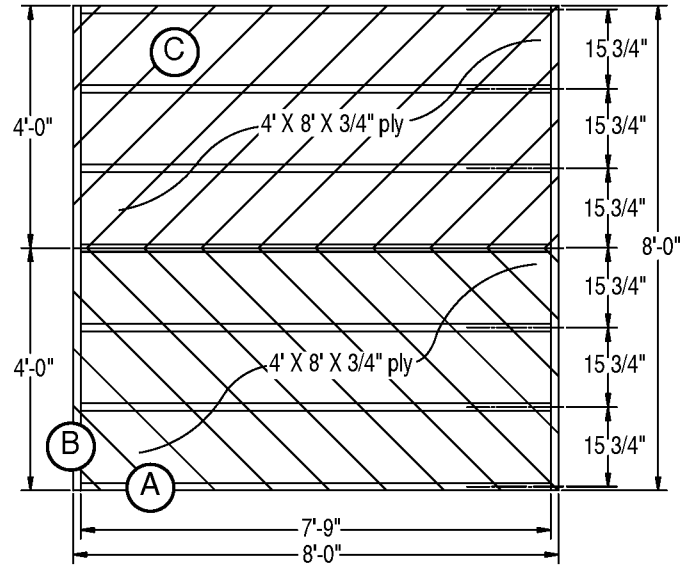

7 1/2' x 10'

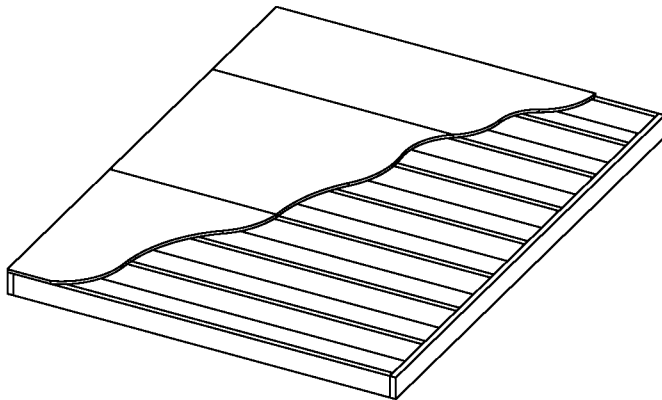

Materials List:

Item	Qty	Size
A	(9)	2" X 6" X 7'-9"
B	(2)	2" X 6" X 10'-6"
C	(2)	4' X 8' X 3/4" Plywood
D	(1)	2'-6" X 8' X 3/4" Plywood

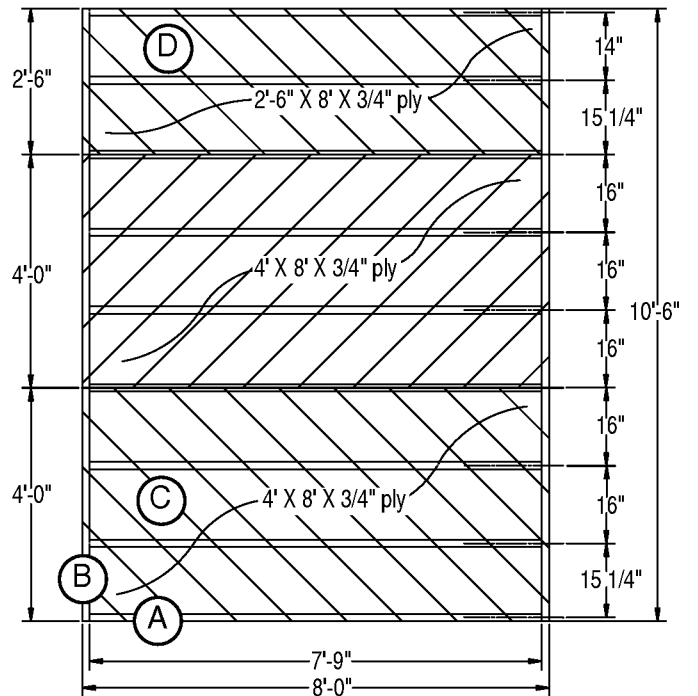

Shed Assembly

NOTE: Site preparation and foundation construction are required for this shed.

Placing the shed on the ground without any type of foundation is not recommended. Without a foundation, settling will probably occur, causing distortion and damage to the shed. Suncoast is not responsible for replacing parts damaged or property lost due to incorrect assembly.

NOTE: Complete site preparation and foundation construction before unpacking parts and beginning assembly.

When assembling shed, light duty work gloves are recommended.

1. With side with opening facing the center of Floor Panels F-A, insert three B Floor Connector Posts into one F-A. Snap into place.

Repeat for each F-A Floor Panel.

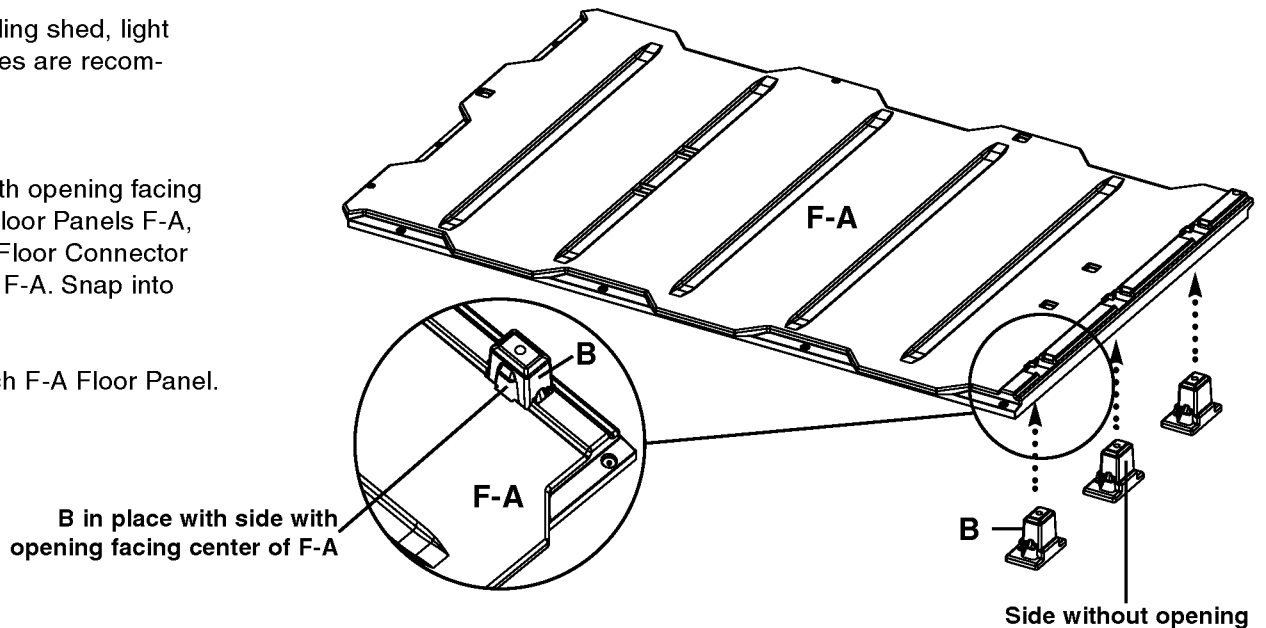

2. Place two F-A Floor Panels next to each other and slide together. Secure with #8-10 x 3/4" Pan Head Screws.

DO NOT OVERTIGHTEN SCREWS.

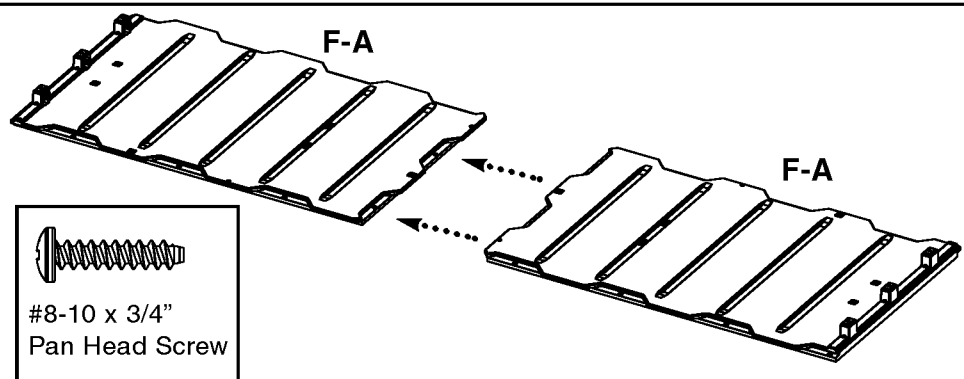

3. Position next F-A Floor Panel and slide together. Secure with #8-10 3/4" Pan Head Screws.

DO NOT OVERTIGHTEN SCREWS.

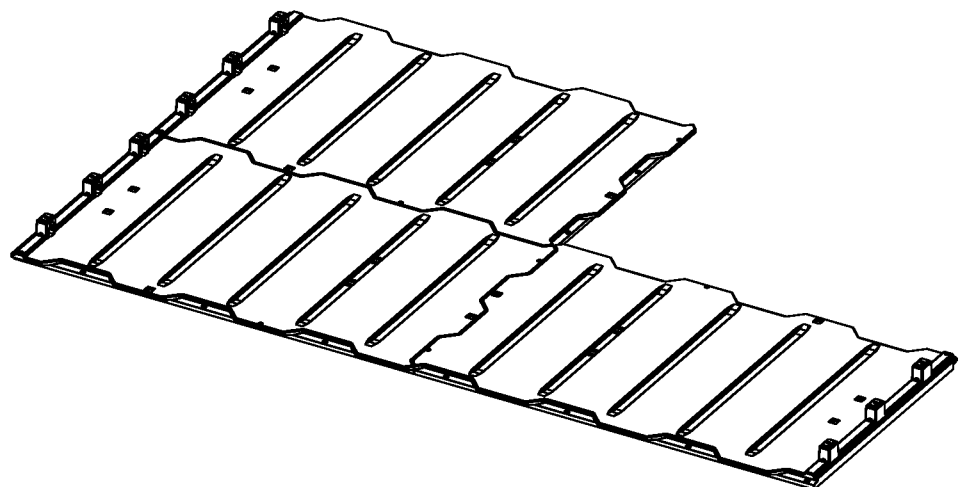

4. Complete shed floor for your shed size. Secure with #8-10 x 3/4" Pan Head Screws.

The number of #8-10 x 3/4" Pan Head Screws used depends on the size of shed being constructed. Please look at the below chart to verify you have the correct number.

DO NOT OVERTIGHTEN SCREWS.

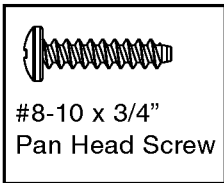

Shed size	Number of #8-10 x 3/4" Pan Head Screws
7 1/2' x 7 1/2'	32
7 1/2' x 10'	38

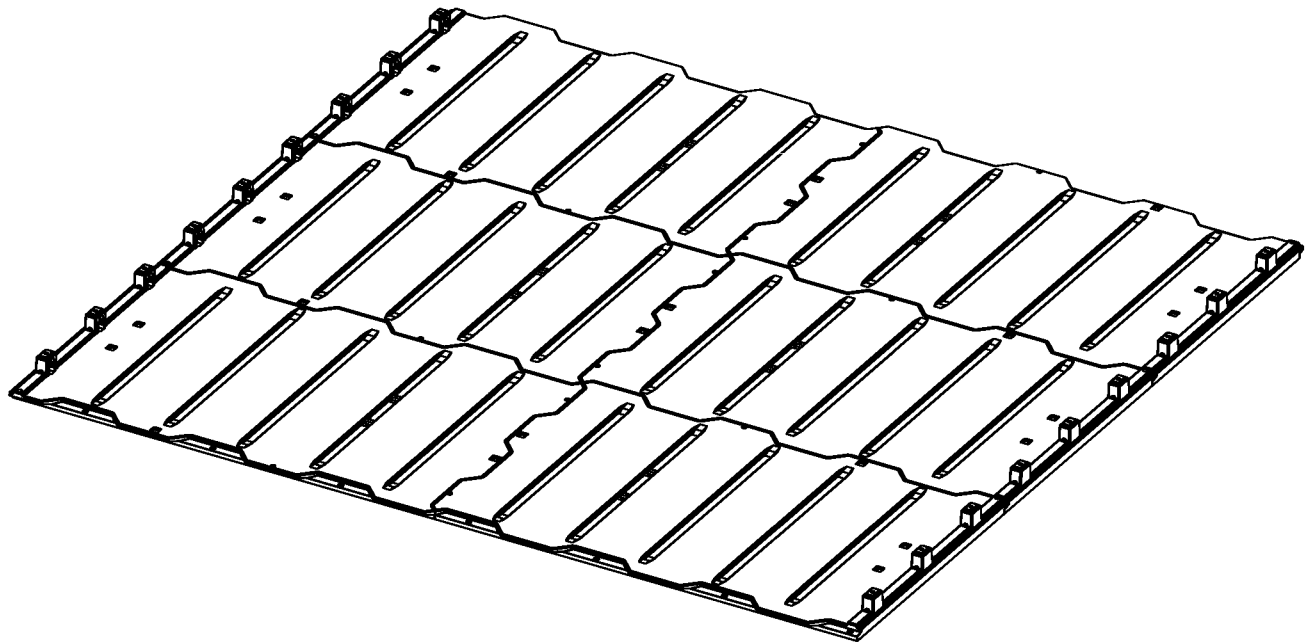

7 1/2' x 7 1/2'

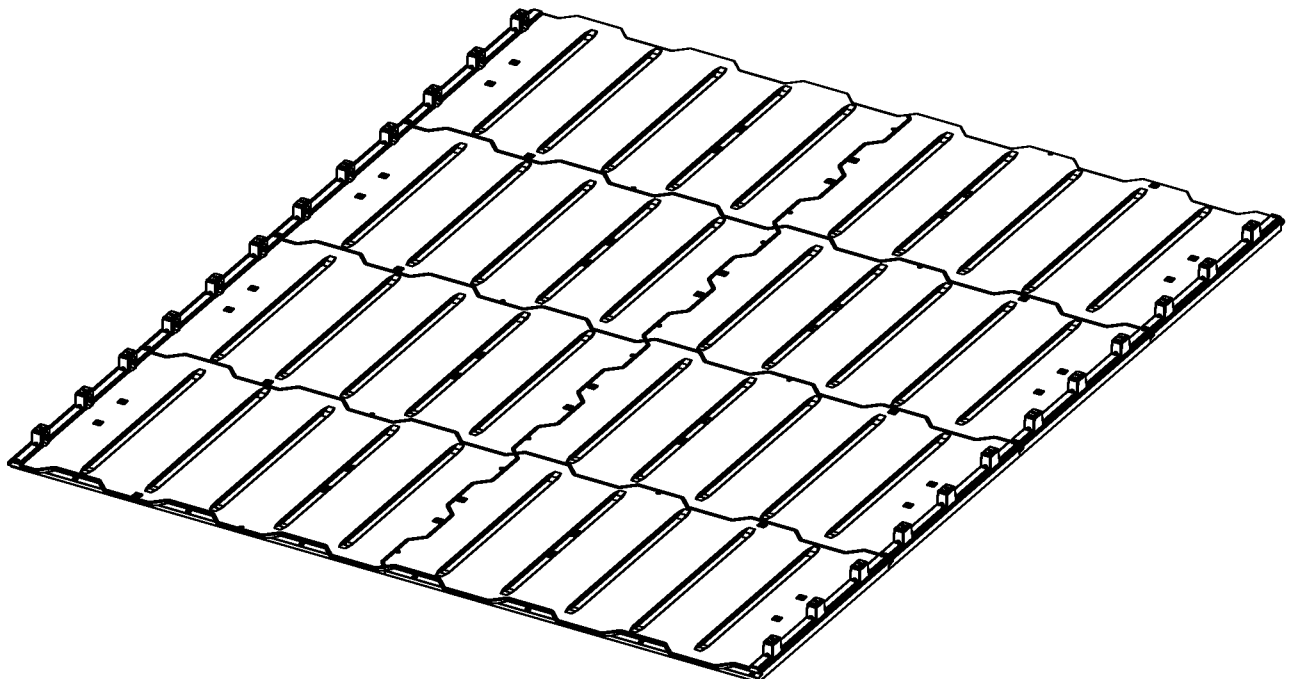

7 1/2' x 10'

5. Designate one side to be the front of the shed.

Place Floor to Front Connector JJ-A in front of left front Floor Panel and slide together. Secure with #8-10 x 3/4" Pan Head Screws.

DO NOT OVERTIGHTEN SCREWS.

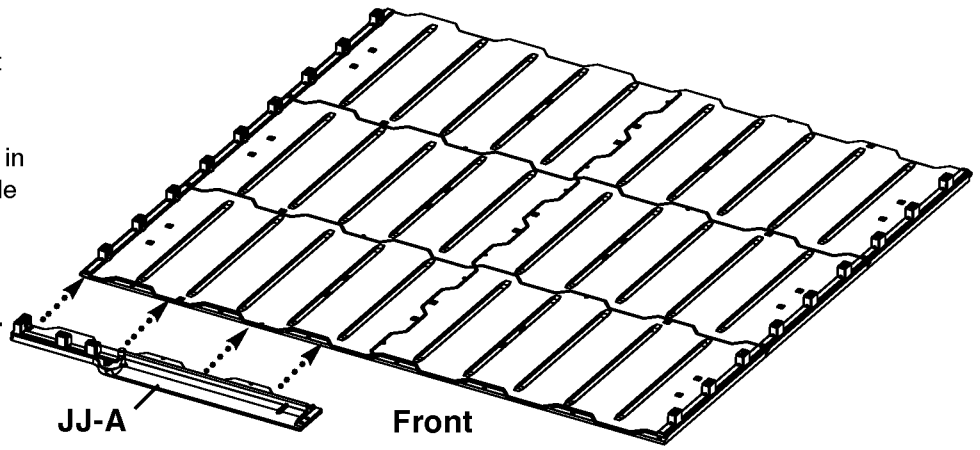

6. Place Floor to Front Connector KK-A in front of right front Floor Panel and slide together. Make sure KK-A overlaps JJ-A where the two meet.

Secure with #8-10 x 3/4" Pan Head Screws.

DO NOT OVERTIGHTEN SCREWS.

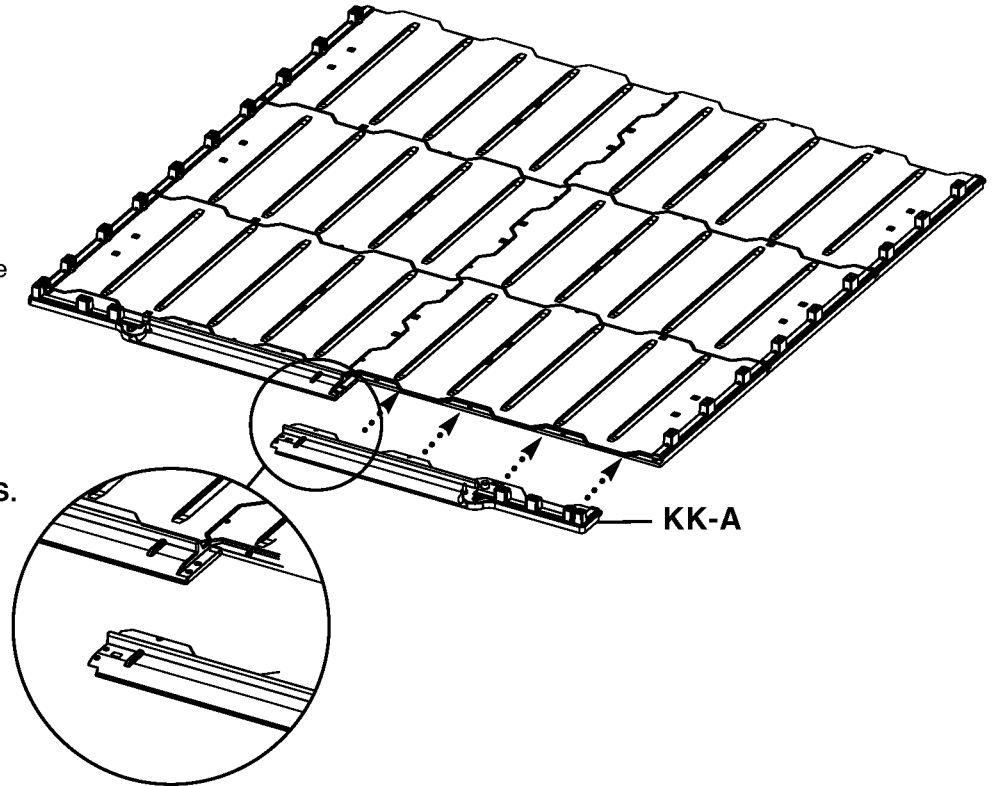

7. Place Floor to Back Connector NN-A in front of right back Floor Panel and slide together. Secure with #8-10 x 3/4" Pan Head Screws.

DO NOT OVERTIGHTEN SCREWS.

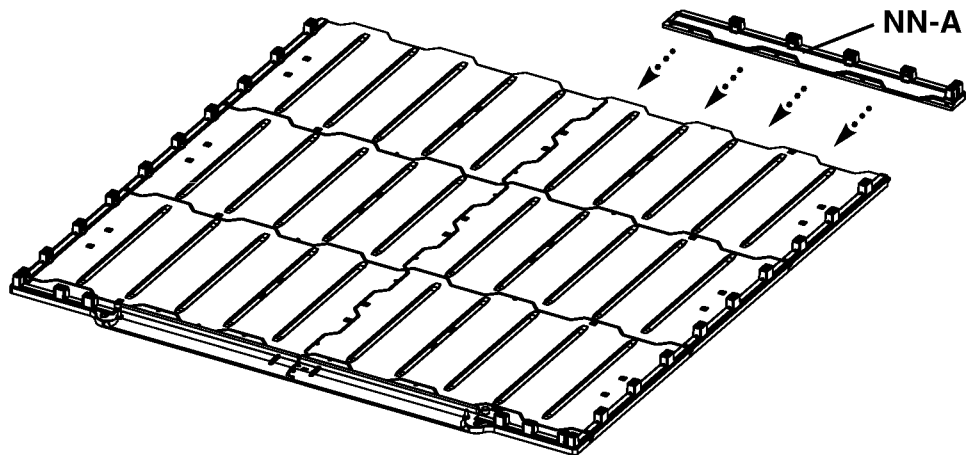

8. Place Floor to Back Connector MM-A in front of left back Floor Panel and slide together. Secure with #8-10 x 3/4" Pan Head Screws.

Make sure MM-A overlaps NN-A where the two meet.

DO NOT OVERTIGHTEN SCREWS.

After installing screws check all screw locations to ensure that none were missed.

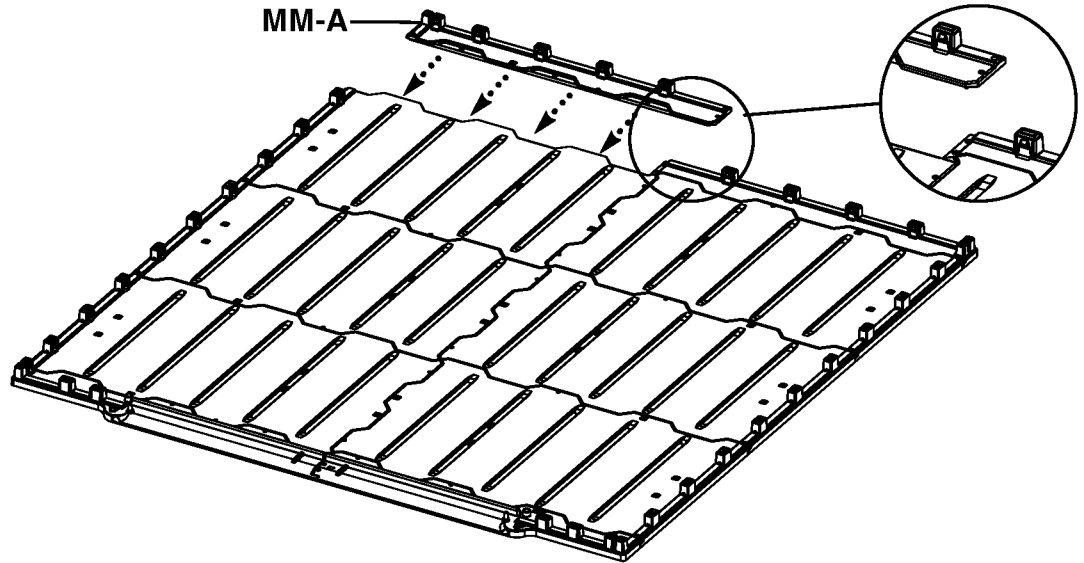

First of two anchor holes in each floor panel

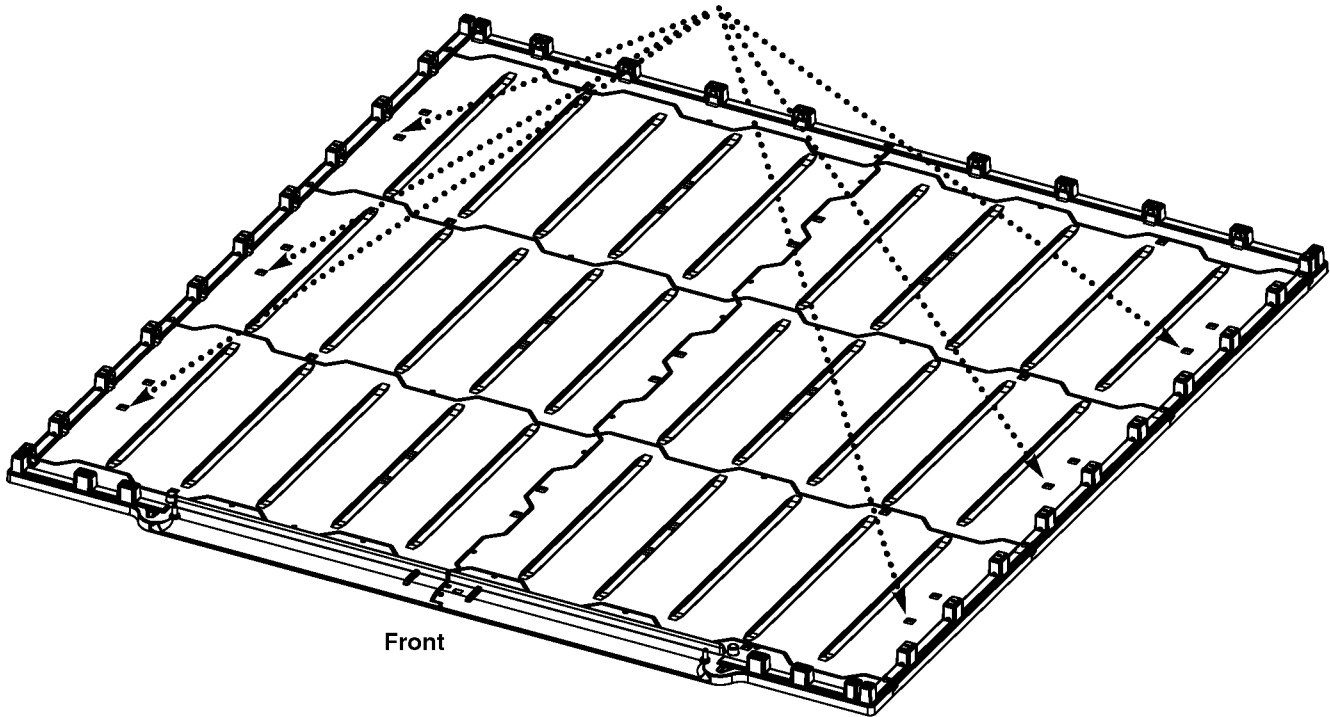

9. To anchor completed floor to foundation (Lag Screws not supplied with Shed kit):

- Consult your local retailer for help to determine the best anchoring method for your particular installation.
- To secure the shed to a concrete pad, use masonry fasteners available at your local retailer.
- To secure the shed to a wood platform, use 1/4" X 2" long lag screws with washers.
- See diagram for anchoring locations.

The number of Lag Screws used depends on the size of shed being constructed. Please look at the below chart to verify you purchase the correct number.

Shed size	Number of Lag Screw
7 1/2' x 7 1/2'	6
7 1/2' x 10'	8

10. Place Female Corner Post G on a flat surface with the embossed G facing up.

Hold Male Corner Post H above Female Corner Post G, making sure the hook end of Male Corner Post H is at one end and the embossed G of Female Corner Post G is at the other end.

Align male and female parts and insert H into G.

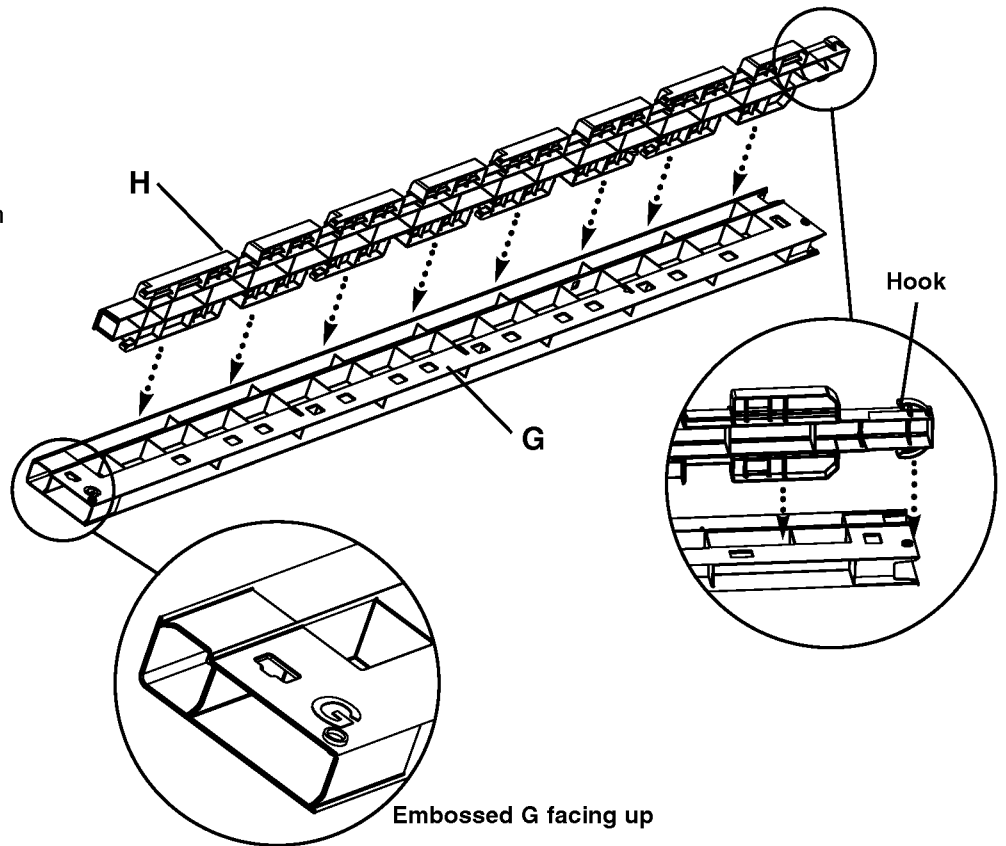

11. Slide Male Corner Post H down Female Corner Post G until parts snap in place.

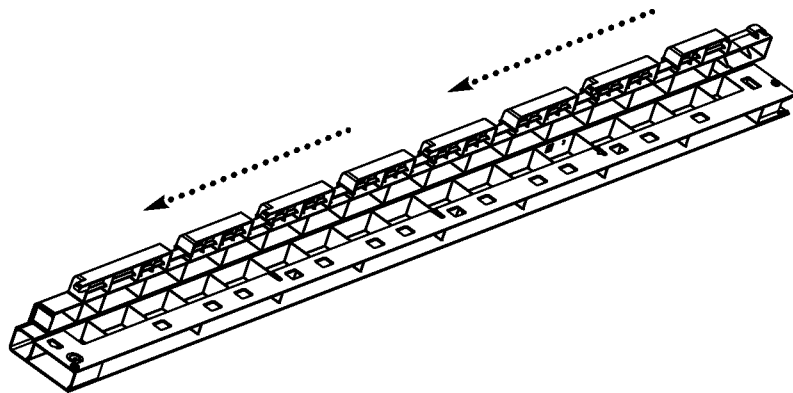

12. Assembled G/H Corner Post.

Repeat process to assemble other 3 corner posts. When complete, set Corner Post Assemblies G/H aside for later use.

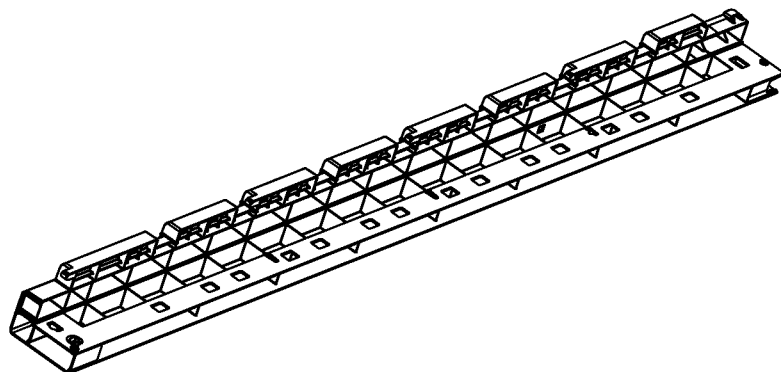

13. Place Front Panel A-A on flat surface.

Place Left Hinge Post P next to Front Panel A-A. Align male and female parts and insert A-A into P.

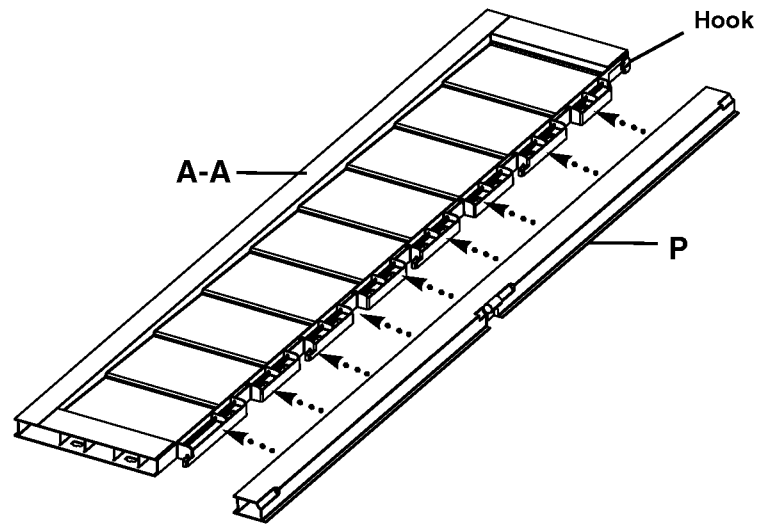

14. Slide Left Hinge Post P up Front Panel A-A until parts snap in place.

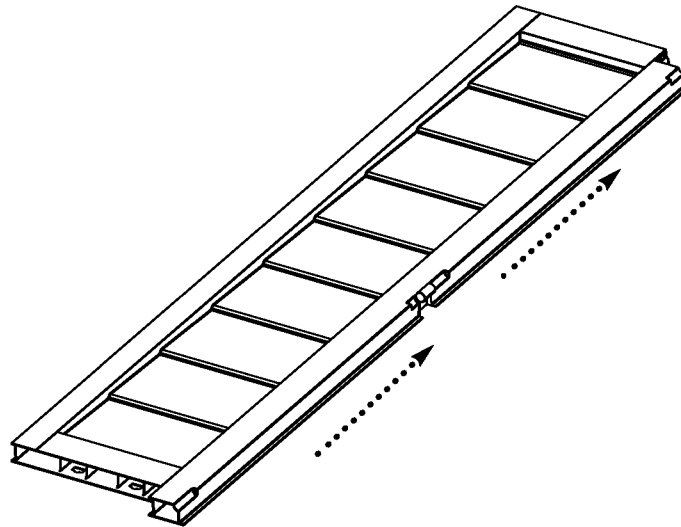

15. Assembled Left Front Panel A-A/P.

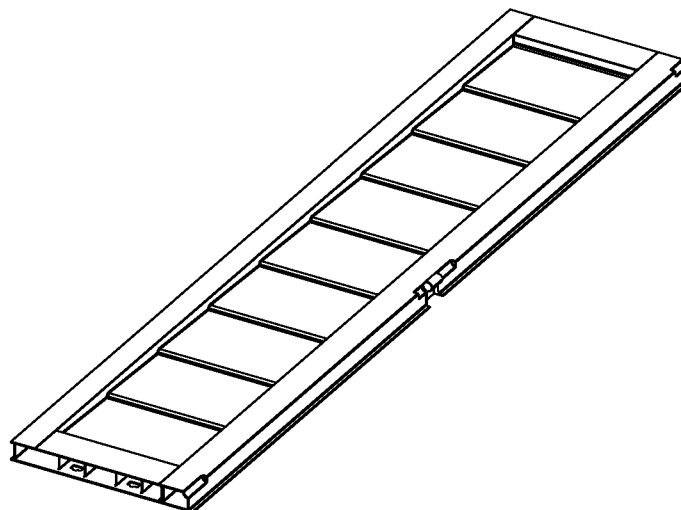

16. Align assembled Left Front Panel A-A/P with left front Floor to Front Connector JJ-A. **Do Not place A-A/P over corner post in JJ-A.**

Snap into place.

When complete, have a second person hold panel in upright position to prevent it from falling over.

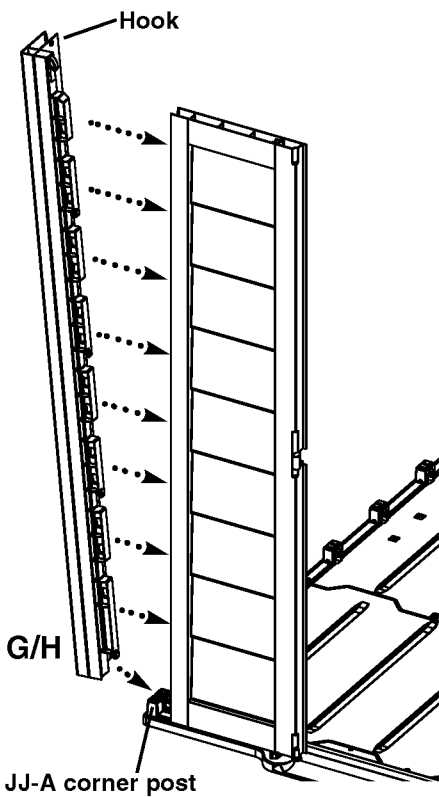
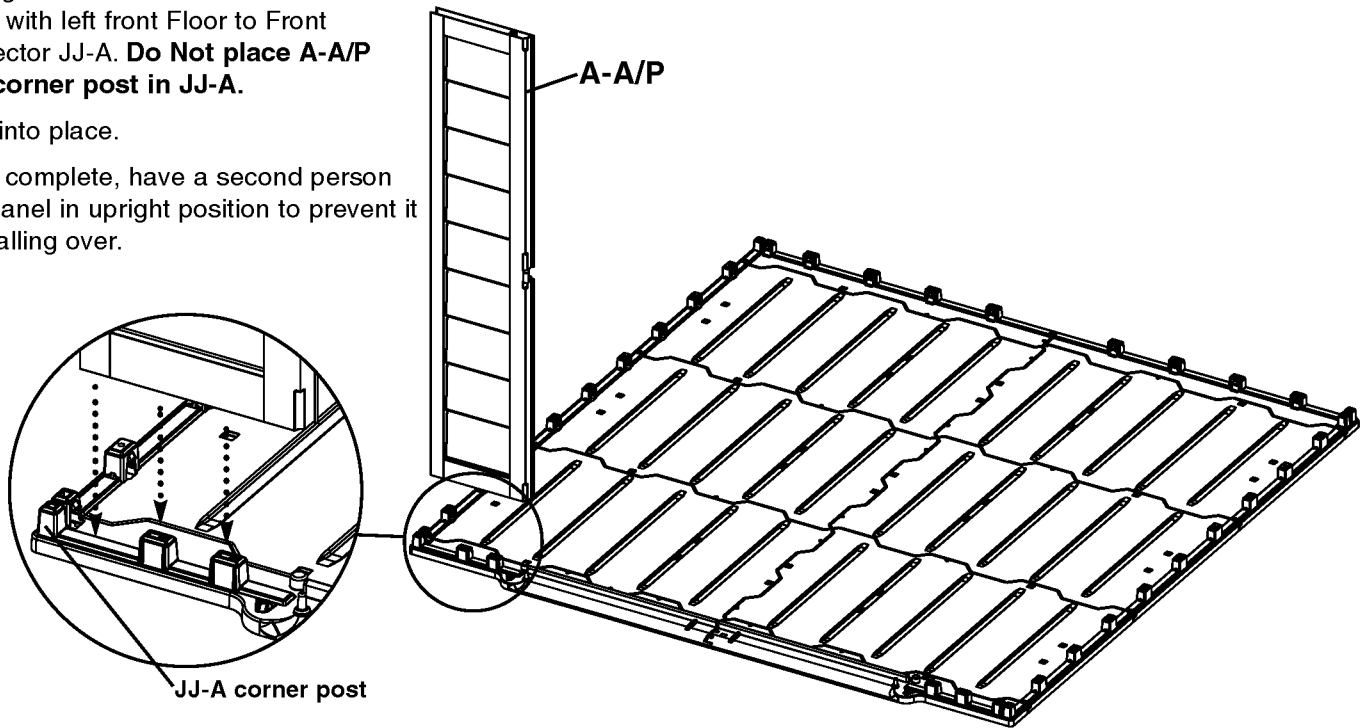

17. With Hook end up, align bottom of Corner Post Assembly G/H with corner post in Floor to Front Connector JJ-A.

Rotate G/H until male parts are inserted into Left Front Panel.

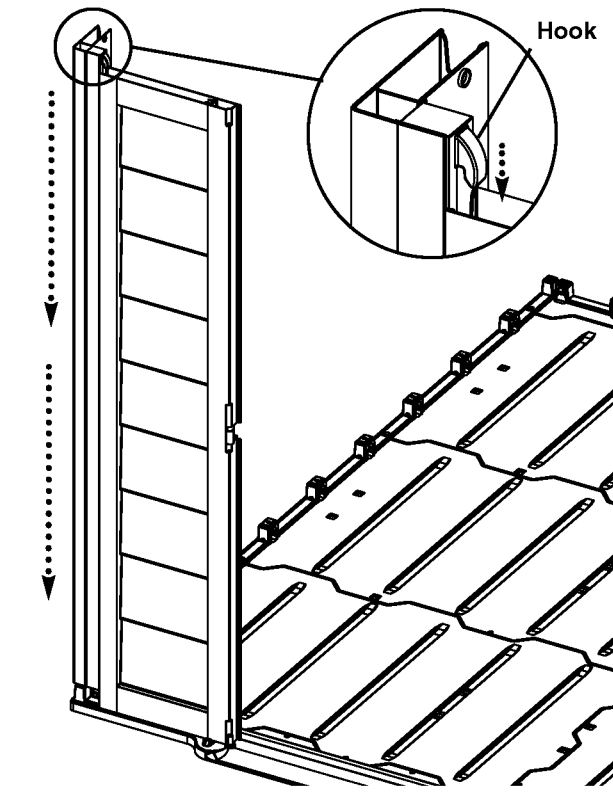

18. Slide Corner Post Assembly G/H down Front Panel A-A/P. Make sure the hook of the Corner Post Assembly hooks over the wall of Panel A-A/P and push down to snap in place.

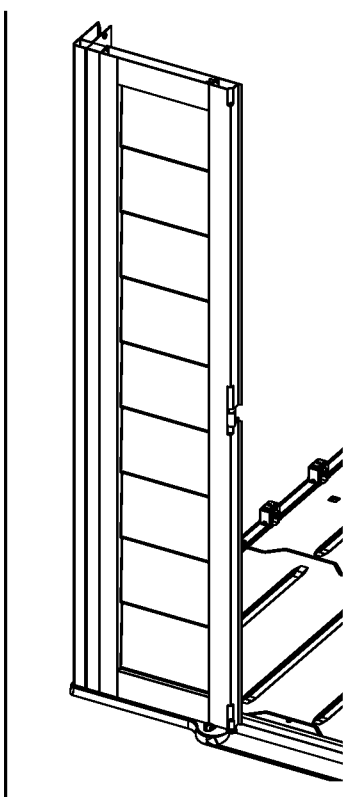

19. Assembled Left Front Panel and Corner Post.

20. Take one S Panel, and place it so the Hook is on top and facing Corner Post Panel G.

Align male and female parts; make sure the hook on Panel S hooks over the wall of Corner Post G/H, and push down to snap in place.

NOTE: If your shed model includes Side Panels with Windows, determine desired window location at this time. Side Panels with Windows may not be used as the panels on either side of the doors. If Shutters are used, Windows cannot be placed in corner positions.

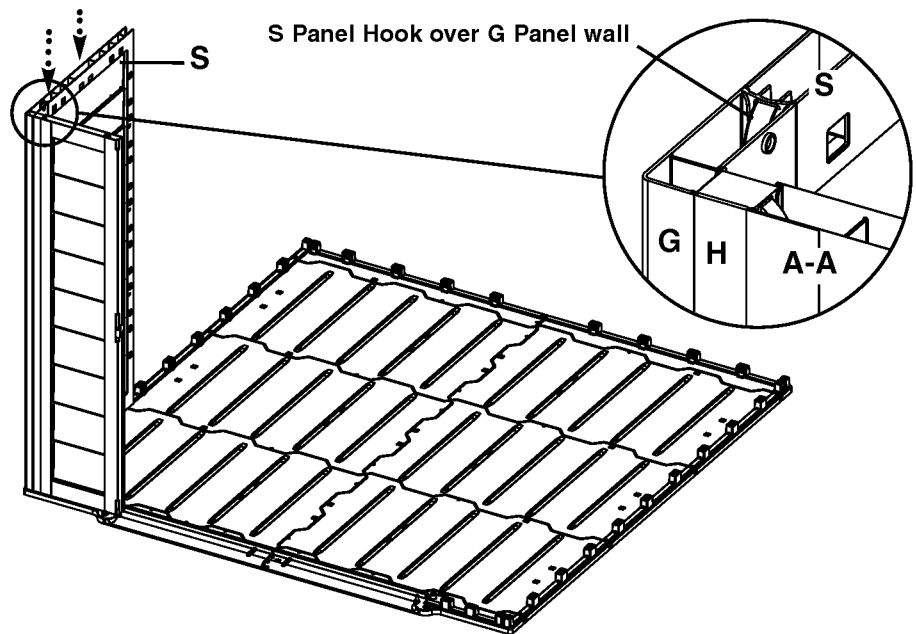

21. Repeat process for second Side Panel S; make sure that the hook on second Side Panel S hooks over the wall of the first Side Panel S and push down to snap in place.

Repeat process to assemble the appropriate number of Side Panels to complete the left side for your shed size.

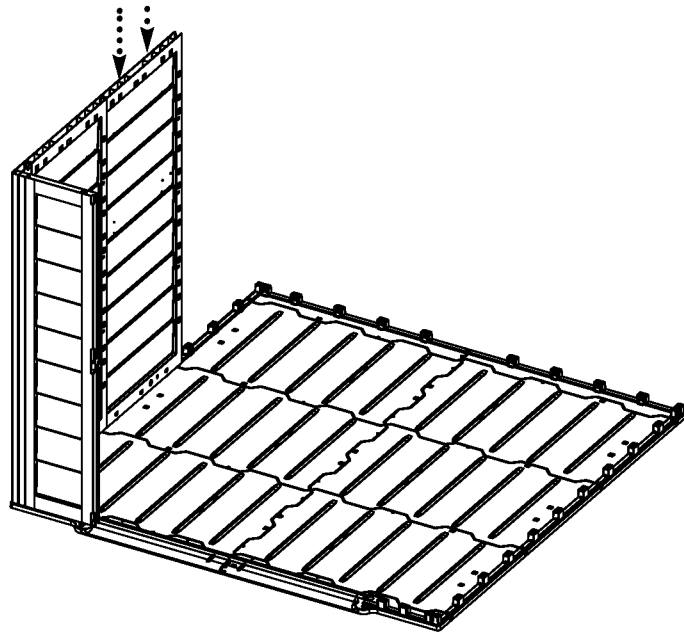

22. With hook end up, align second assembled Corner Post with last Side Panel S. Align male and female parts and insert assembled Corner Post into S.

Slide assembled Corner Post down Side Panel S, making sure the hook of the assembled Corner Post hooks over the wall of Panel S and push down to snap in place.

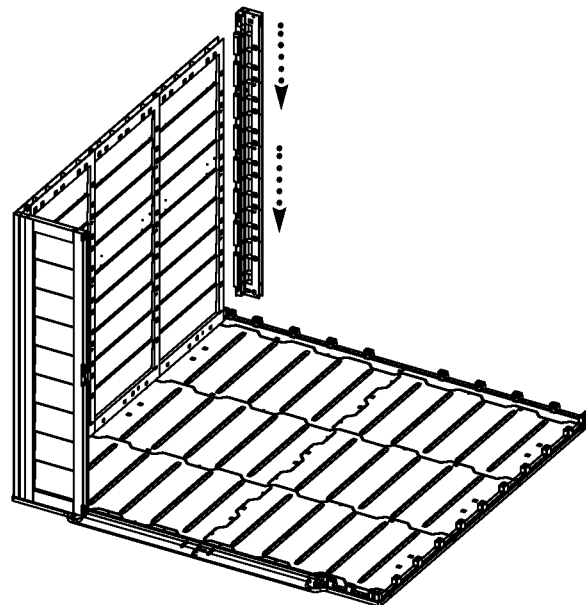

23. Take one S Panel and place it so the hook is on top and faces Corner Post G/H.

Align male and female parts. Make sure the hook on Side Panel S hooks over the wall of Corner Post G/H and push down to snap in place.

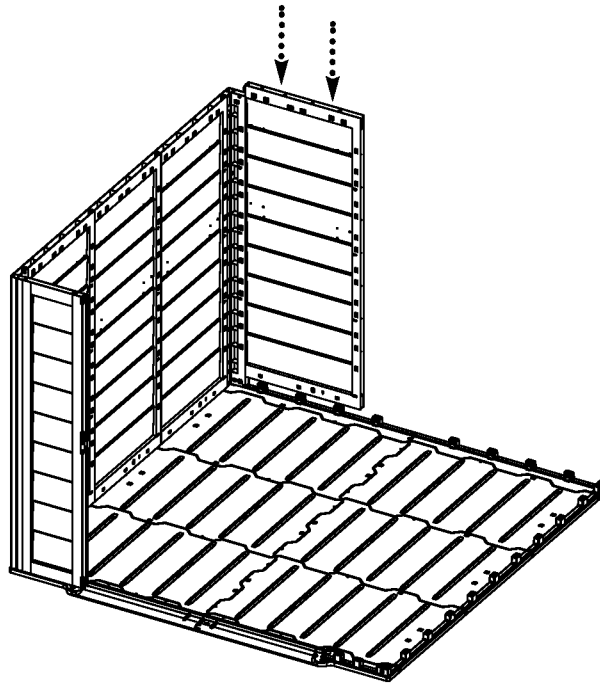

24. Complete side and corner assembly process for your shed size. The remaining Front Panel A-A will be the last panel installed.

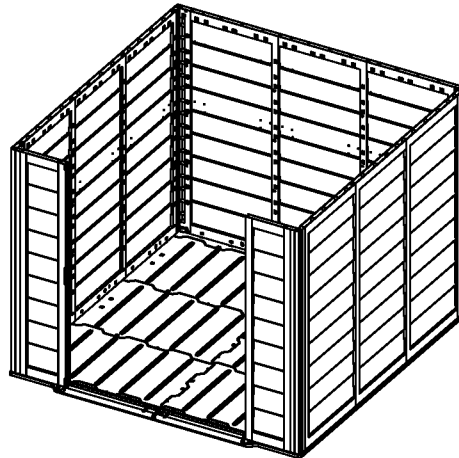

7 1/2' x 7 1/2'

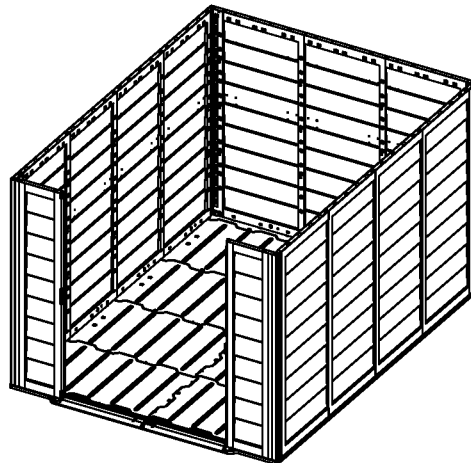

7 1/2' x 10'

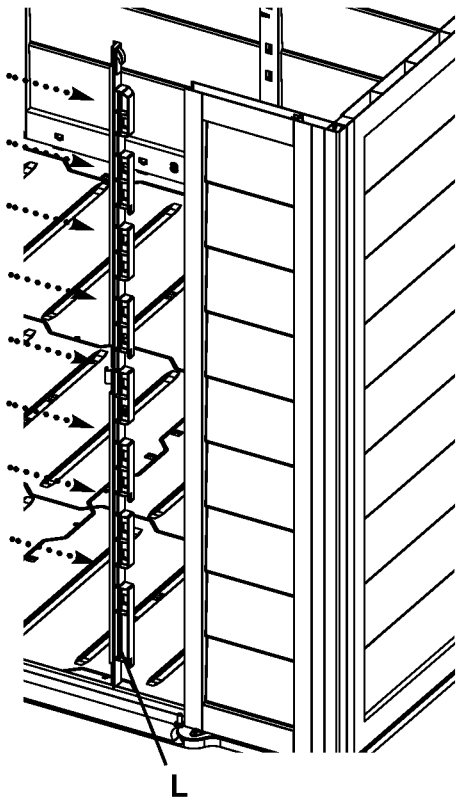

25. With Hook end up, place Right Hinge Post L next to Right Front Panel A-A. Align male and female parts and insert L into A-A.

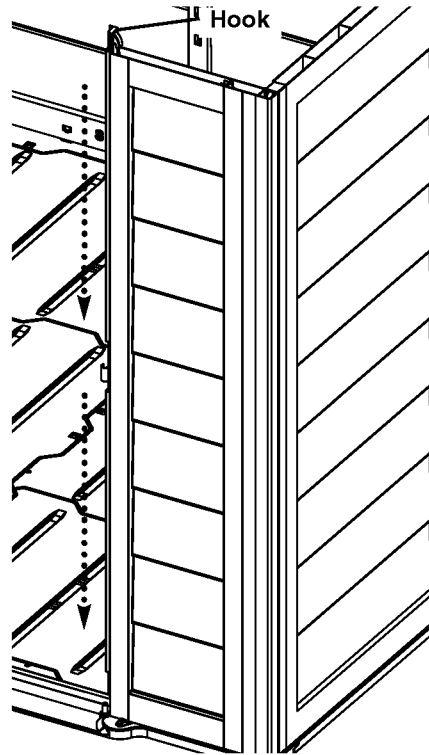

26. Slide Right Hinge Post L down Front Panel A-A. Make sure the hook at the top of the Right Hinge Post hooks over the wall of Panel A-A and push down to snap in place.

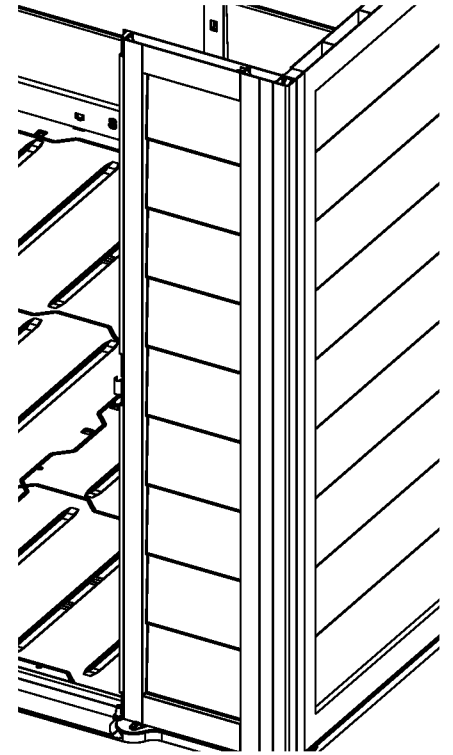

27. Assembled Right Front Panel and Hinge Post A-A/L.

28. Make sure that all panels are securely in place.

Check all snaps to verify they are fully engaged.

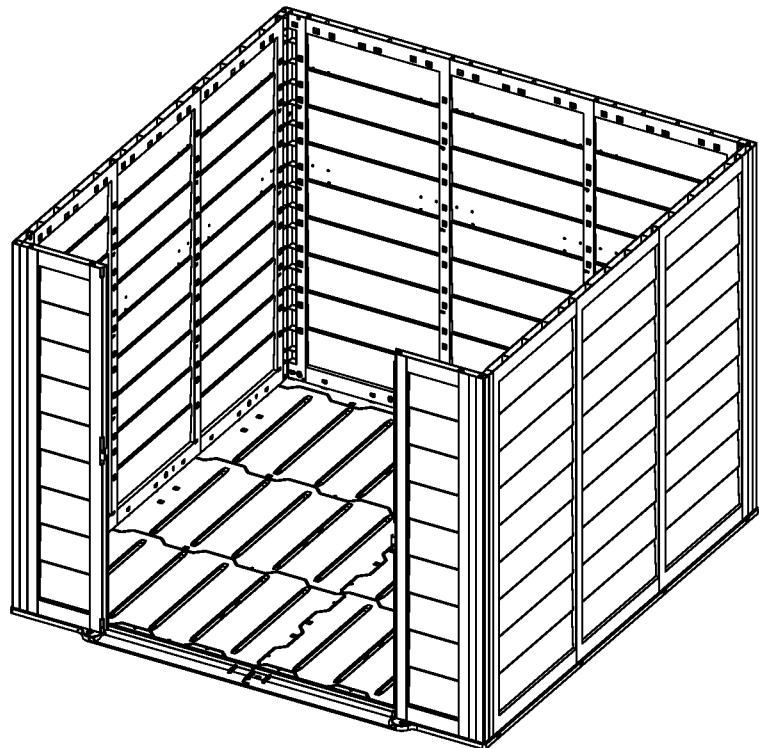

29. Standing inside shed, locate the Header Support Tube Bracket receptacles midway up from the floor on Front Panel A-A/L.

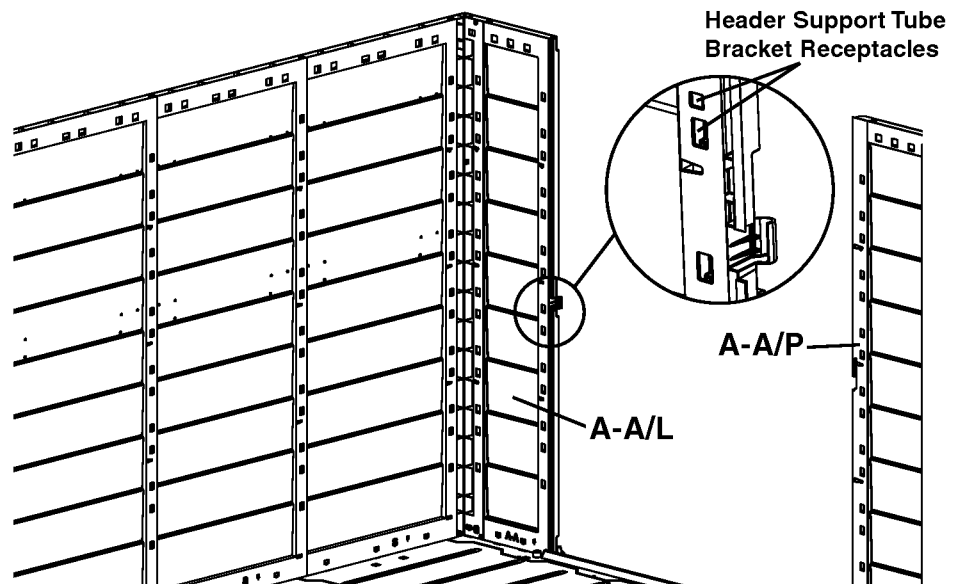

30. Align Header Support Tube Bracket tabs with receptacles in Panel A-A/L.

Engage the tabs into the two holes in Panel A-A/L and rotate the Bracket downward to snap into place.

Repeat process for second Header Support Bracket in Hinge Panel A-A/P, on other side of doorway.

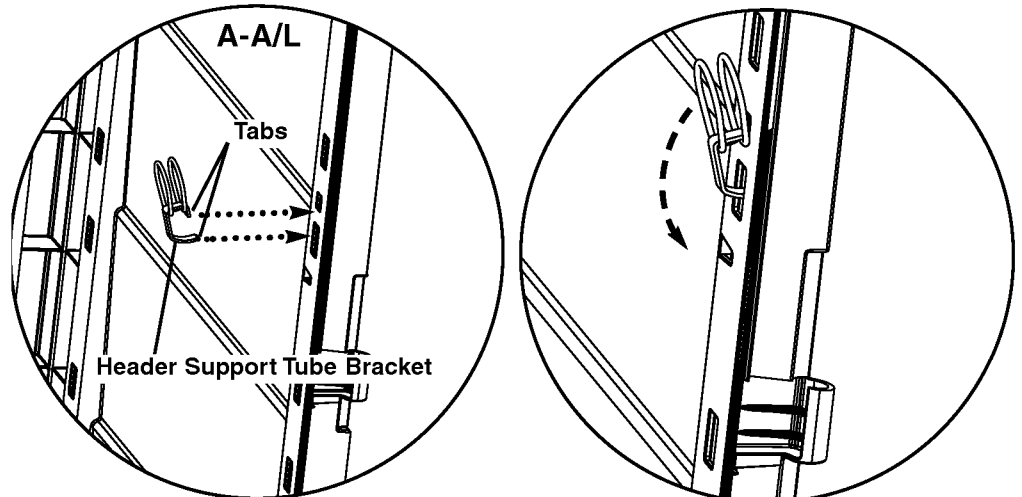

NOTE: Use Caution when handling the Header Support Tubes, especially if other people are nearby. The tubes are long and if not handled with care can cause damage to persons or property.

31. Slide Header Support Tube down through Header Support Tube Bracket and over floor post.

Repeat process for second Header Support Tube.

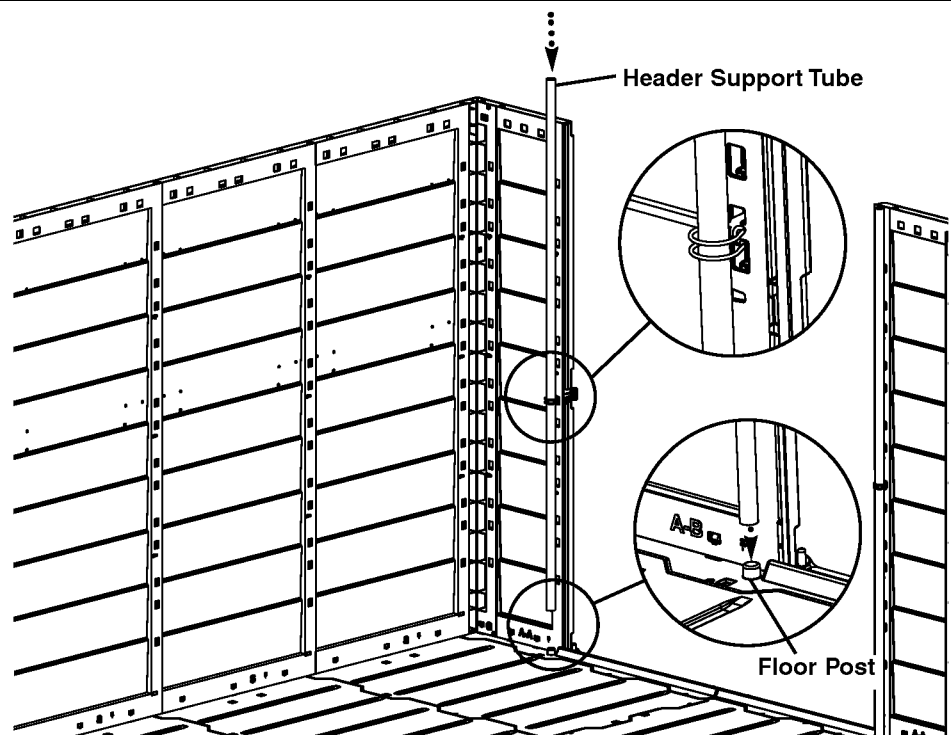

32. To insert Door Latch Housings M, position Tabs so they point towards the edge of the door. Place the Tabs behind the front wall of the door and press until part snaps in place.

Repeat process for second Door Latch Housing M.

NOTE: Door Latch Housings can only be inserted in one direction.

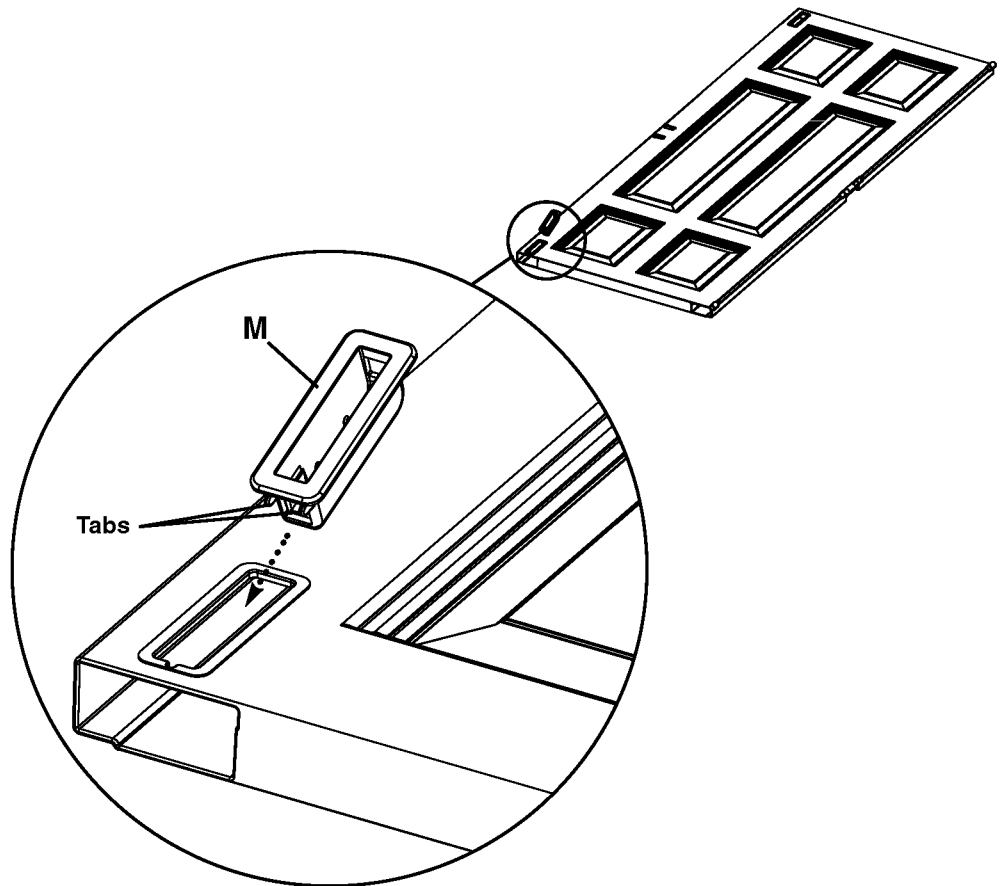

33. Insert square end of Door Latch Pin N into Door Latch Housing M.

For the Door Latch Housing at the BOTTOM of the door you will push the pin **UP** into the Door Latch Housing.

Once square end is inserted, push Door Latch Pin N **downward** to engage snaps that secure it inside housing.

For the Door Latch Housing at the TOP of the door you will push the pin **DOWNWARD** into the Door Latch Housing.

Once square end is inserted, push Door Latch Pin N **upward** to engage snaps that secure it inside housing.

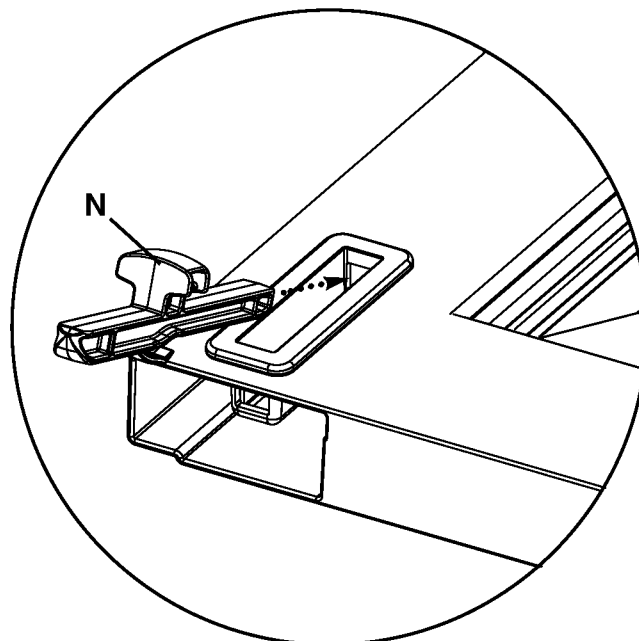

Door Latch Housing at the **BOTTOM** of the door

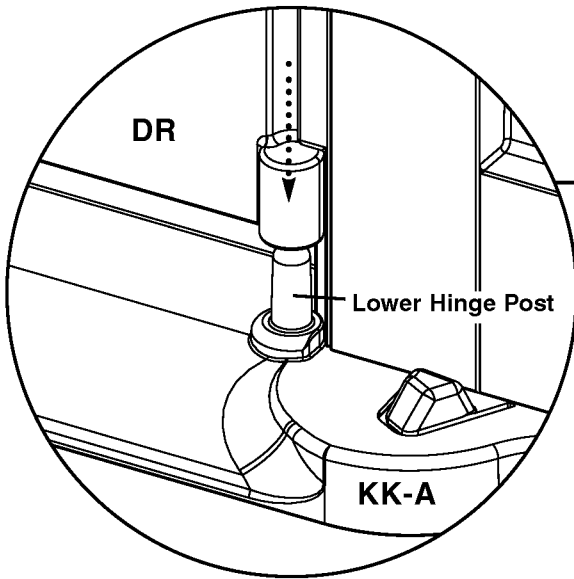
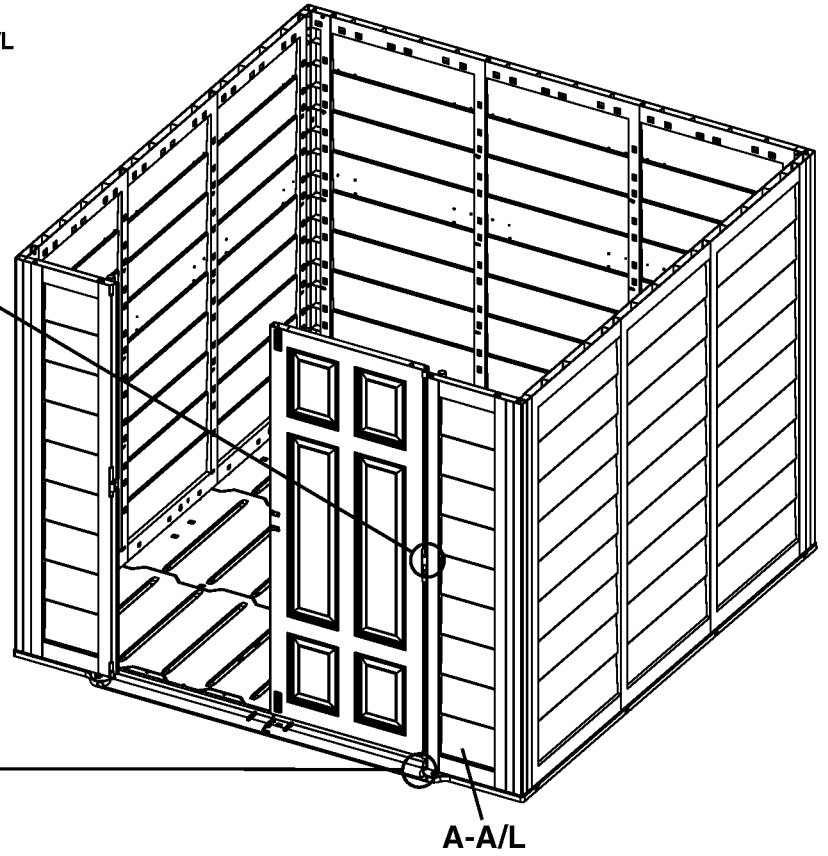
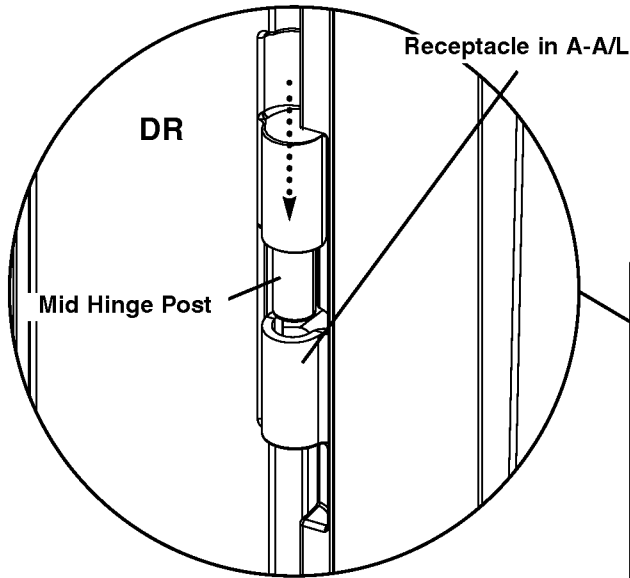

34. With Door DR in the closed position, align Mid Hinge Post with receptacle in Assembled Right Front Panel A-A/L. At the same time, align Lower Hinge Post of Front Connector KK-A with receptacle in Right Door DR and slide down into place.

35. With Right Door in open position, repeat process for Left Door DL.

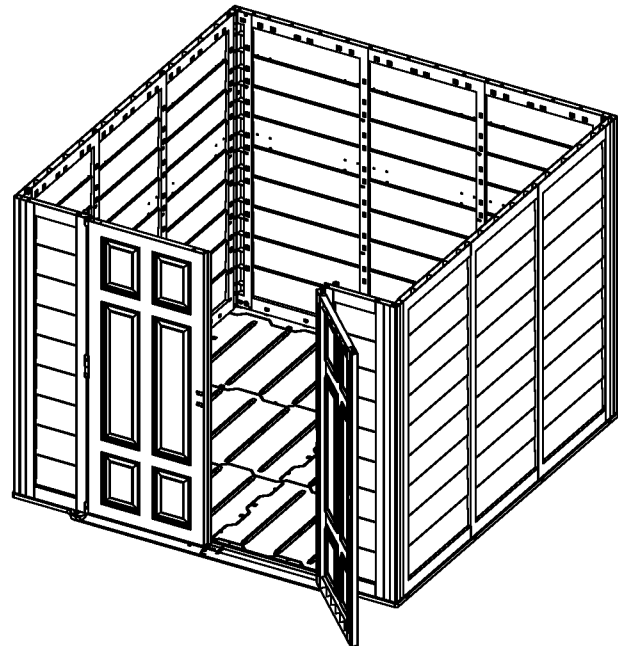

36. Align male and female ends of Header Panels EL and ER. Slide together until the panels snap in place.

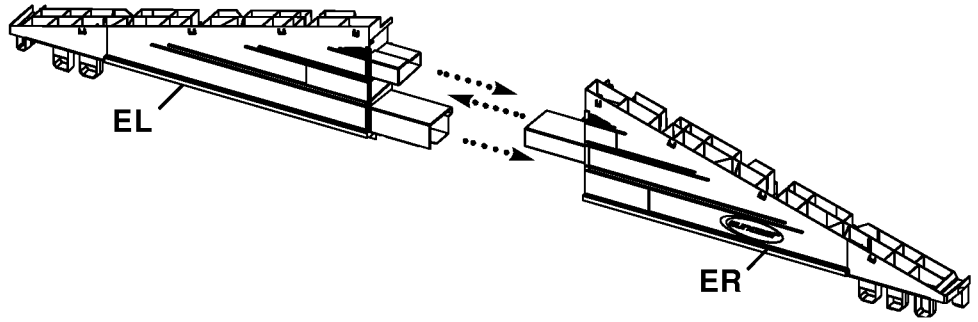

Repeat for second header.

Underside View of Assembled Header

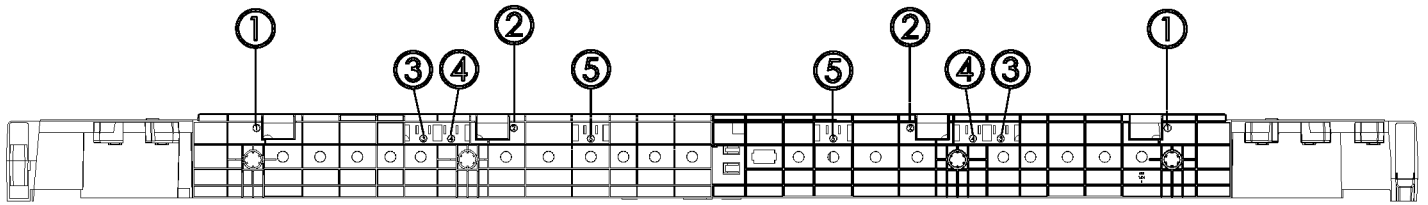

Back to Header Connector R and Hinge Pin DD positions are located by numerals 1 through 5 on the underside of the completed headers.

Not every numeral position will be used.

Please follow the directions closely to ensure the proper positions are used.

Header to Header Connector Y is placed in an unnumbered location where the two headers meet.

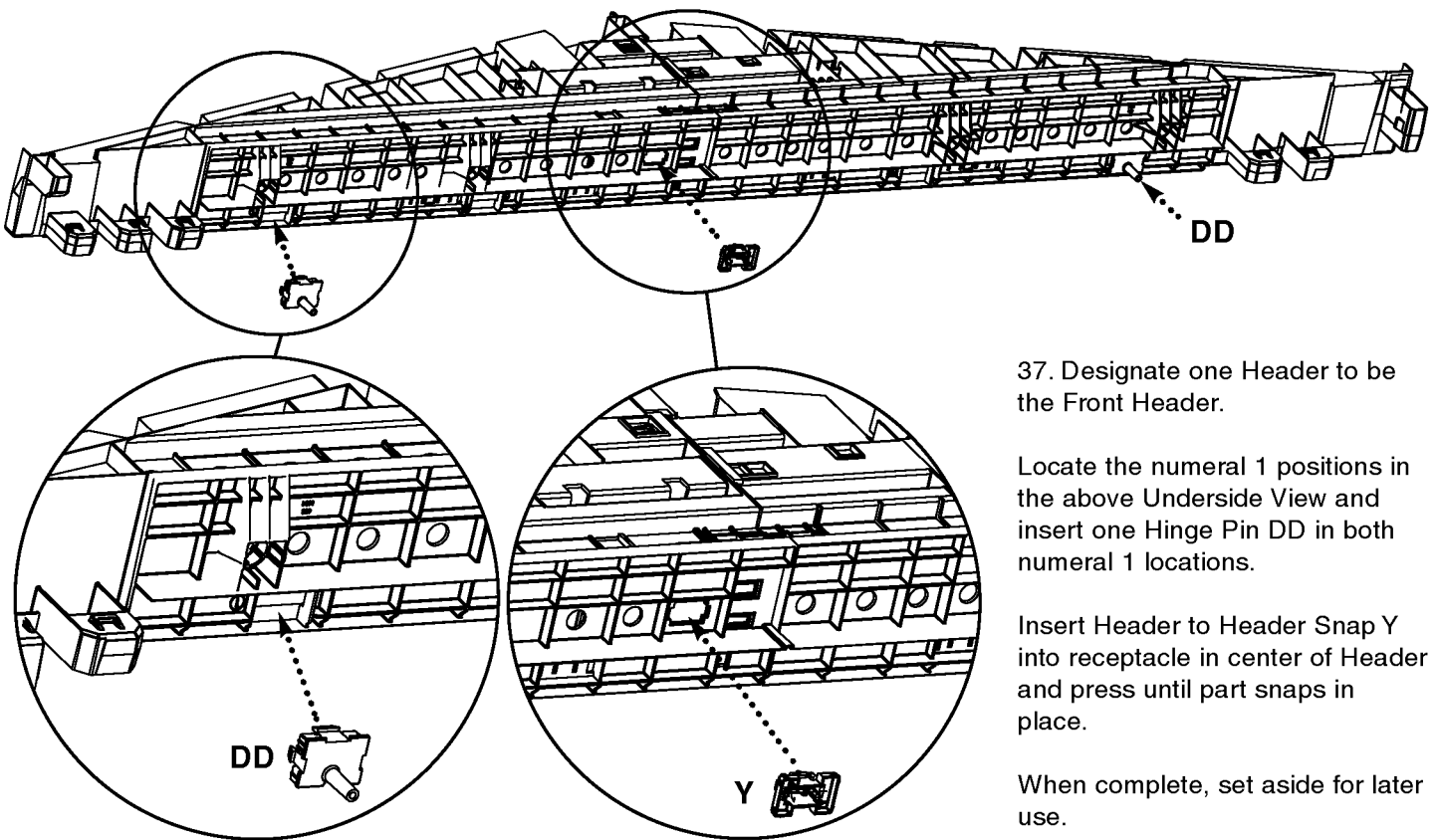
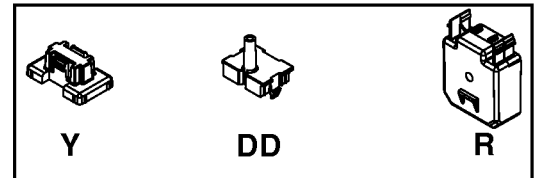

37. Designate one Header to be the Front Header.

Locate the numeral 1 positions in the above Underside View and insert one Hinge Pin DD in both numeral 1 locations.

Insert Header to Header Snap Y into receptacle in center of Header and press until part snaps in place.

When complete, set aside for later use.

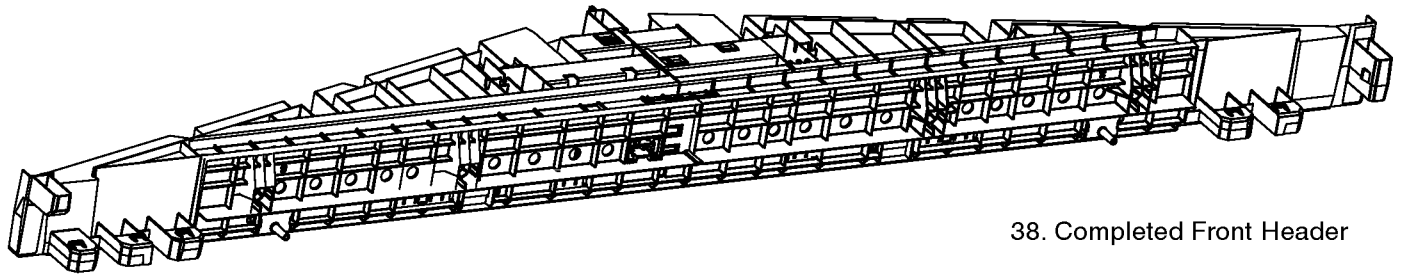

38. Completed Front Header

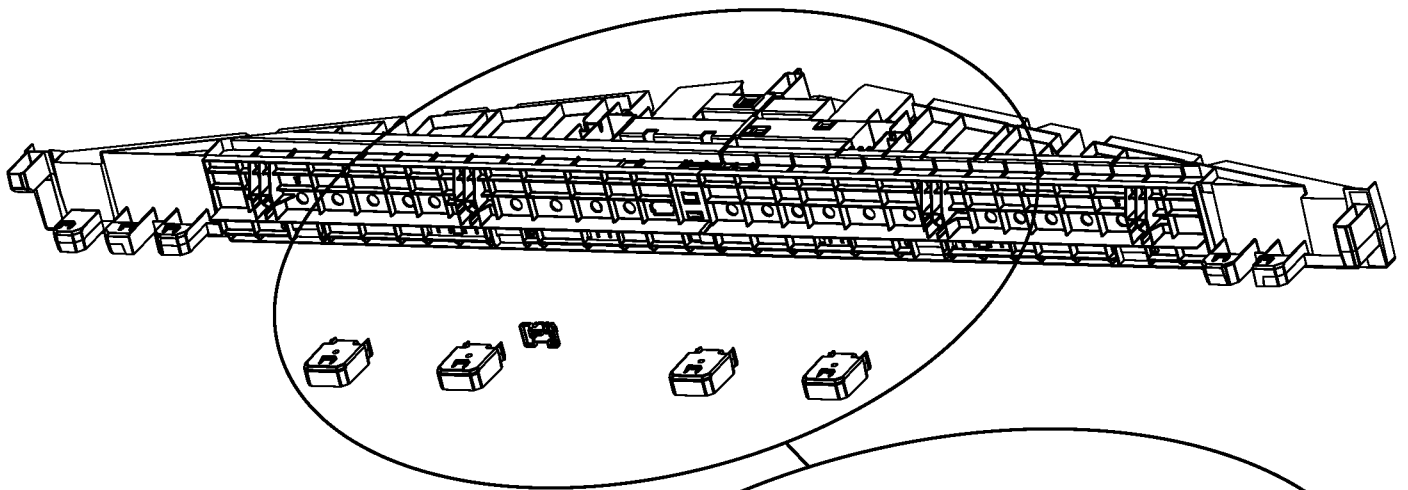

39. The remaining Header is the Back Header.

Locate the numeral 4 and 5 positions in the Underside View on page 24 and insert one Back to Header Connector R in both numeral 4 locations and both numeral 5 locations.

Insert Header to Header Snap Y into receptacle in center of Header and press until part snaps in place.

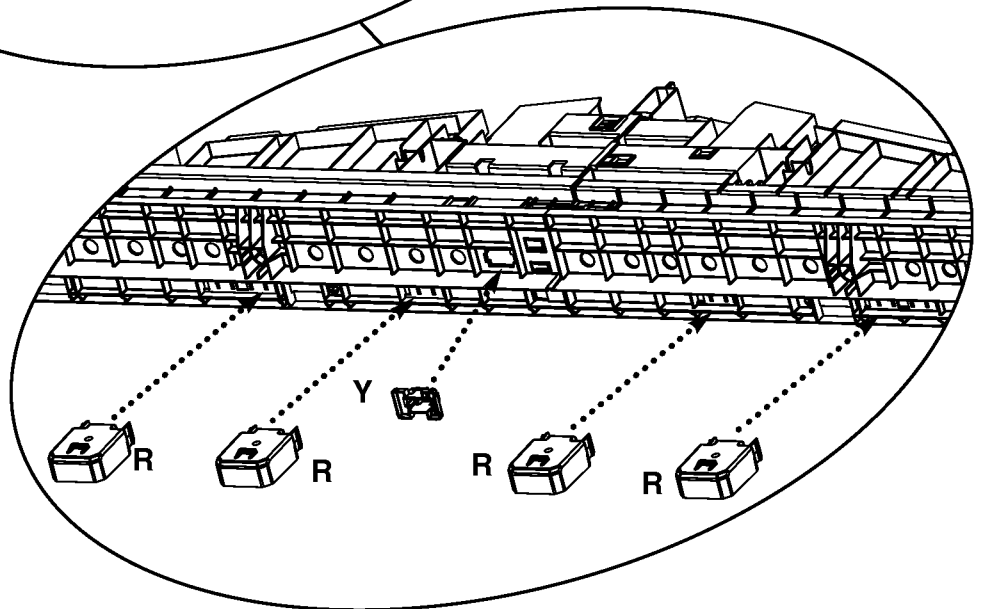

When complete, set aside for later use.

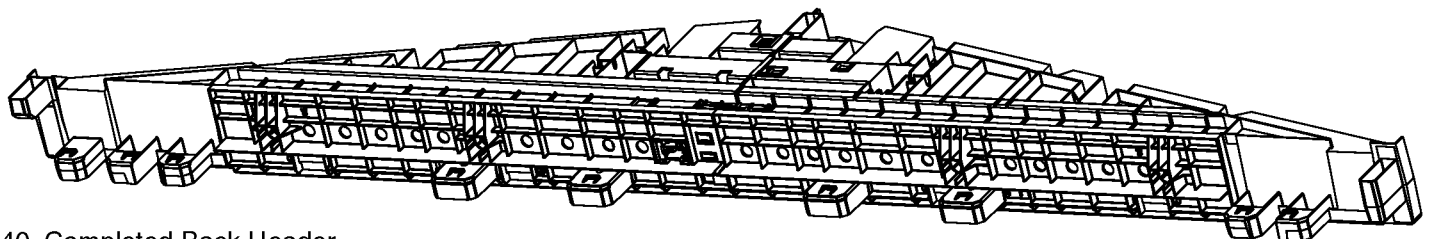

40. Completed Back Header

NOTE: Make sure you have the Front Header in the Front of the Shed and the Back Header in the Back of the Shed.

41. With at least two people, both standing inside the shed, lower Back Header into place.

Do not engage Back Header snaps at this time.

See next two steps for details specific to each Header installation.

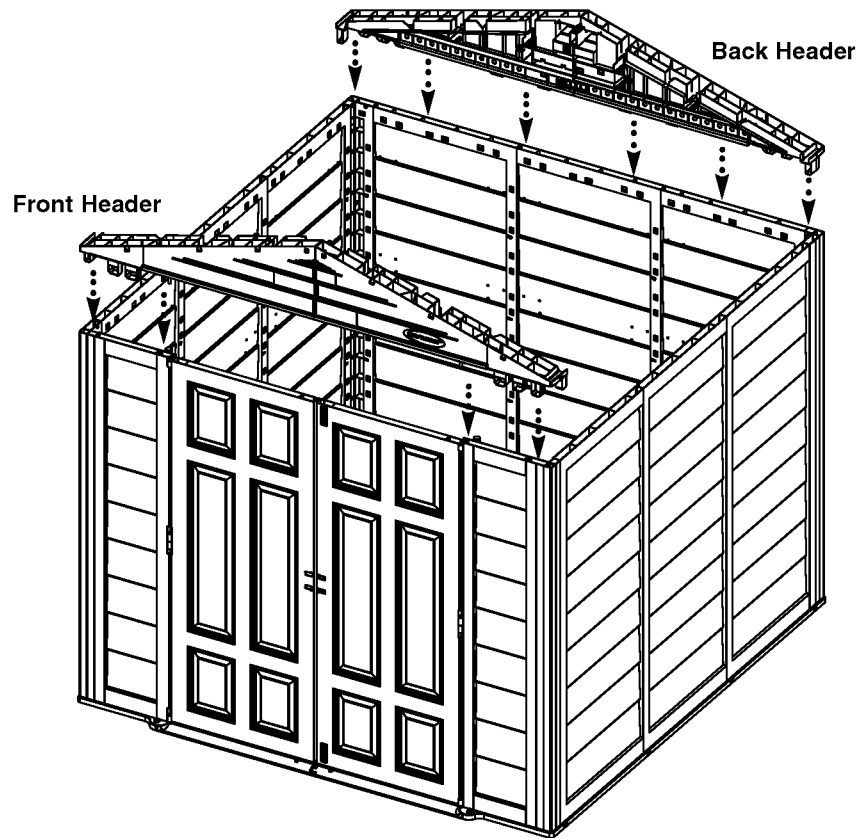

Back Header to Shed

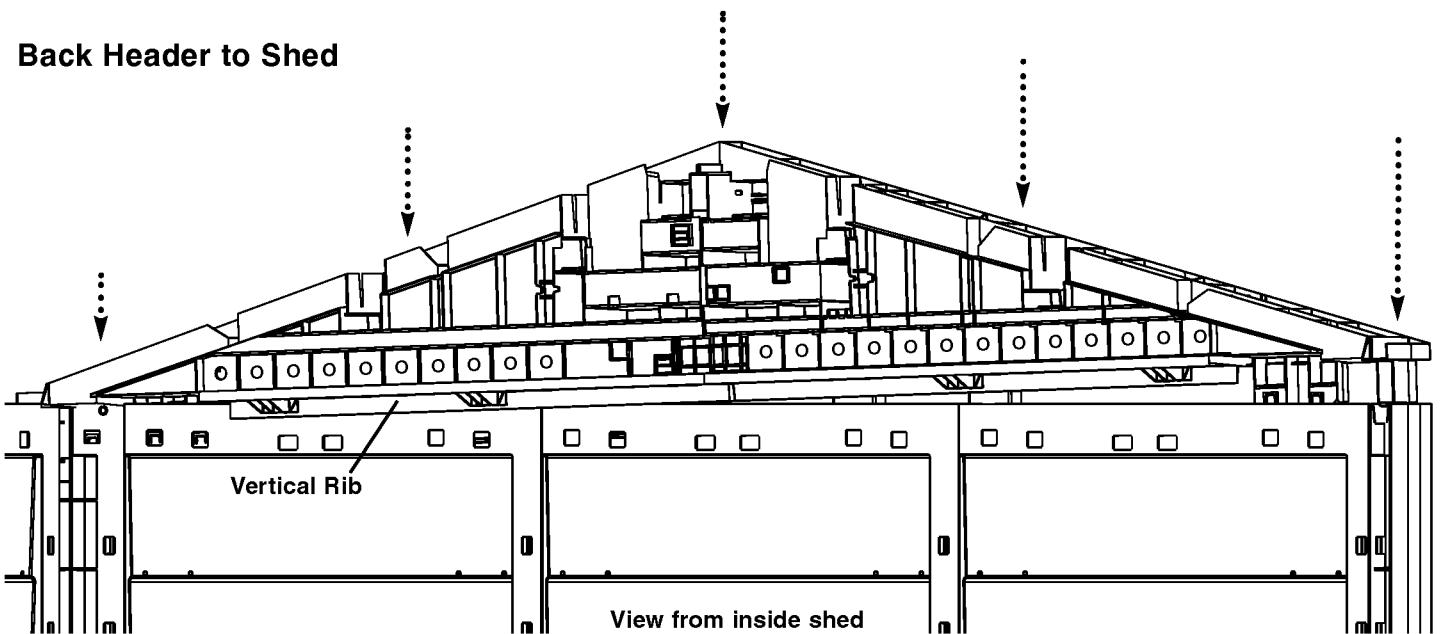

42. From one end, start inserting the Back Header partially into the Side Panels that make up the back of the shed. Begin final installation by pressing downward on one end of the Header.

Guide the vertical rib to the inside of the shed as you move along the Header to the other end. Continue until all snaps are in place.

Front Header to Shed

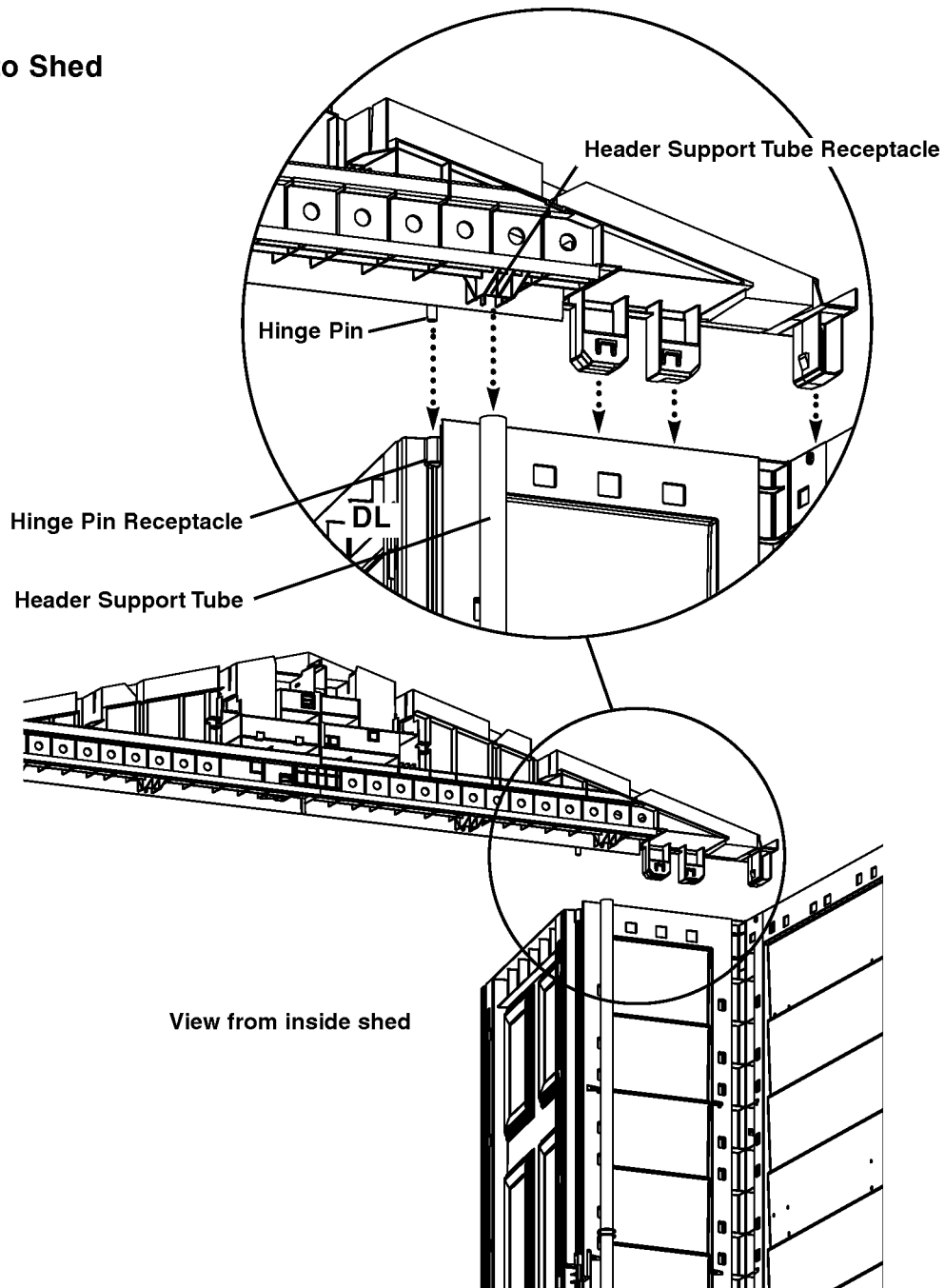

43. Set Doors in open position. With at least two people, one of them standing inside the shed, lower Front Header into place.

Do not engage Front Header snaps at this time.

Align Hinge Pins and Header Support Tube Receptacles in Front Header with Hinge Pin Receptacles and Header Support Tubes.

Begin final installation by pressing downward on one end of the Header and working your way to the other until all snaps are in place.

44. Make sure that both Headers are securely in place.

Check all snaps to verify they are fully engaged.

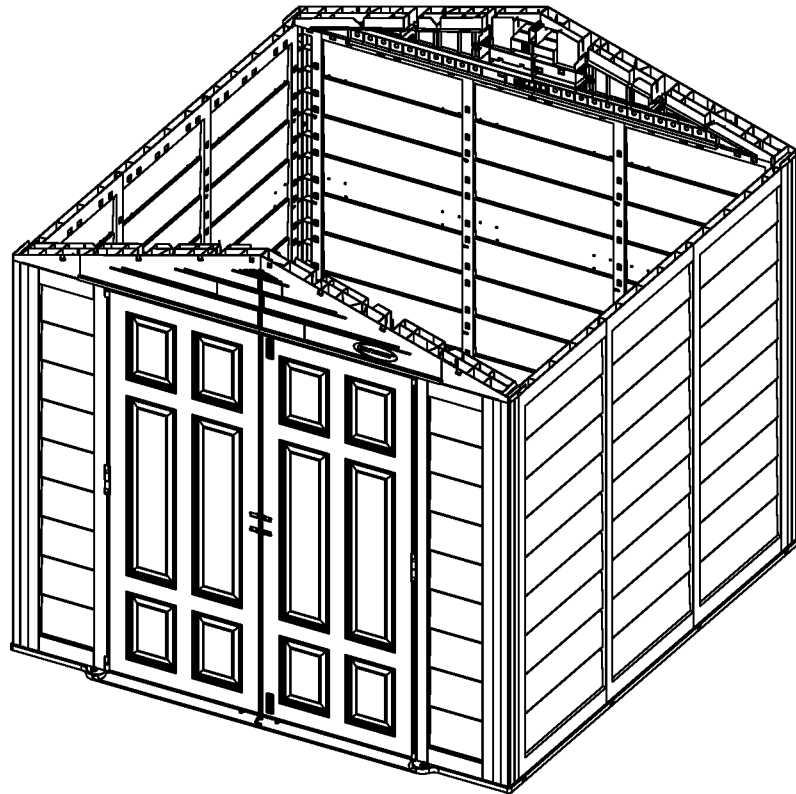

45. Insert one Roof to Side Connector U into each remaining Side Panel. Snap in place.

The number of Roof to Side Connectors U used depends on the size of shed being constructed. Please look at the below chart to verify you have the correct number.

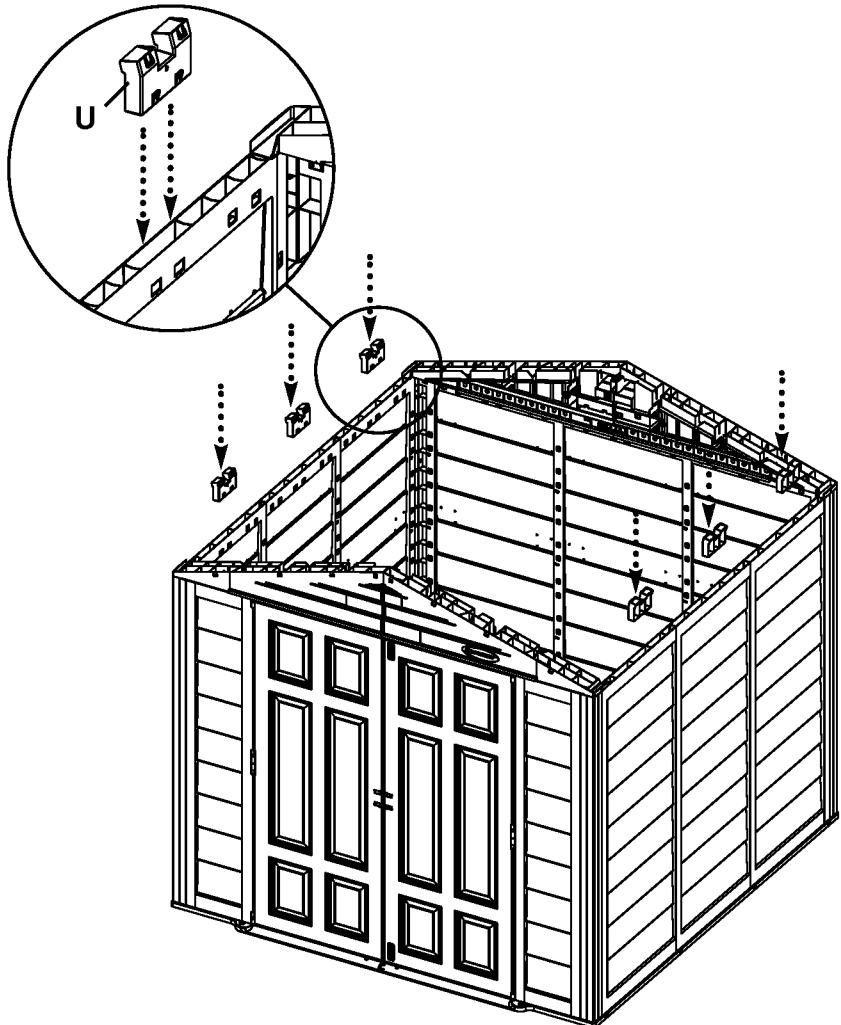

Shed size	Number of Roof to Side Connectors U
7 1/2' x 7 1/2'	6
7 1/2' x 10'	8

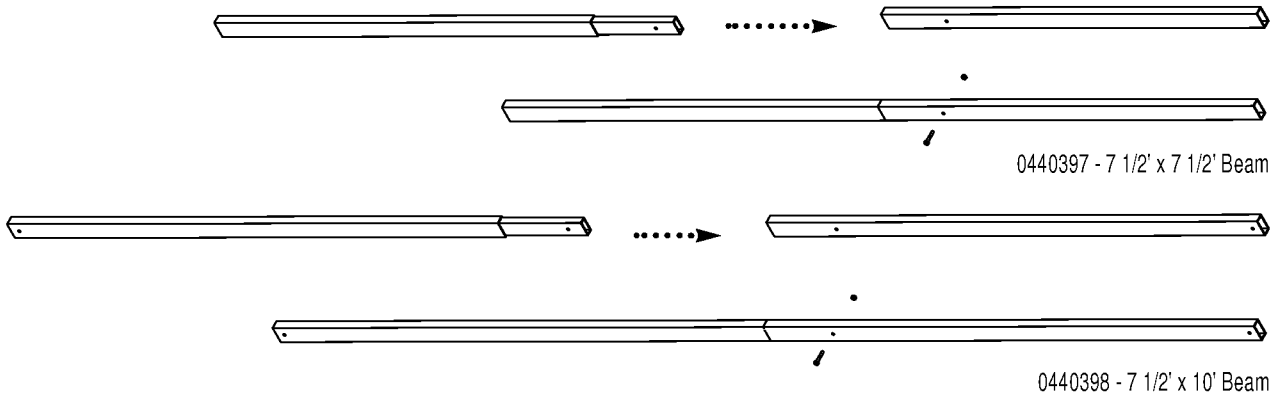

46. Complete Ridge Beam for your shed size by sliding Male Ridge Beam section(s) into Female Ridge Beam section(s).

Secure with provided 1/4"-20- x 1 1/2" Hex Head Cap Bolt and 1/4-20 Hex Nut.

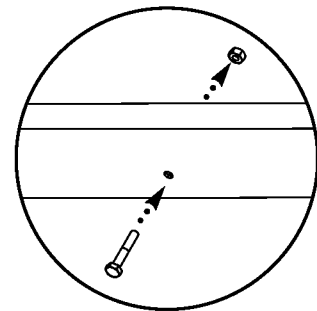
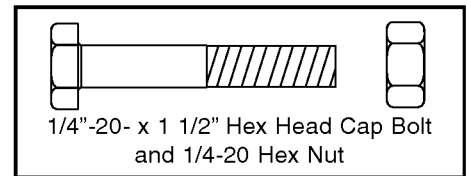

NOTE: Use Caution when handling the Steel Ridge Beams, especially if other people are nearby. The beams are long and if not handled with care can cause damage to persons or property.

47. Standing inside the shed, insert one end of one assembled Steel Ridge Beam into the rectangular boss in the **center** of the Rear Header.

Still standing inside shed, **support the Steel Ridge Beam** and push outward slightly on the Front Header to insert opposite end into the rectangular boss in the center of the Front Header.

Once Beam is in place **DO NOT** push outward on either header, as Beam may fall.

DO NOT stand beneath Beam until Assembled Ridge Panels are in place.

Rectangular boss in center of Front Header

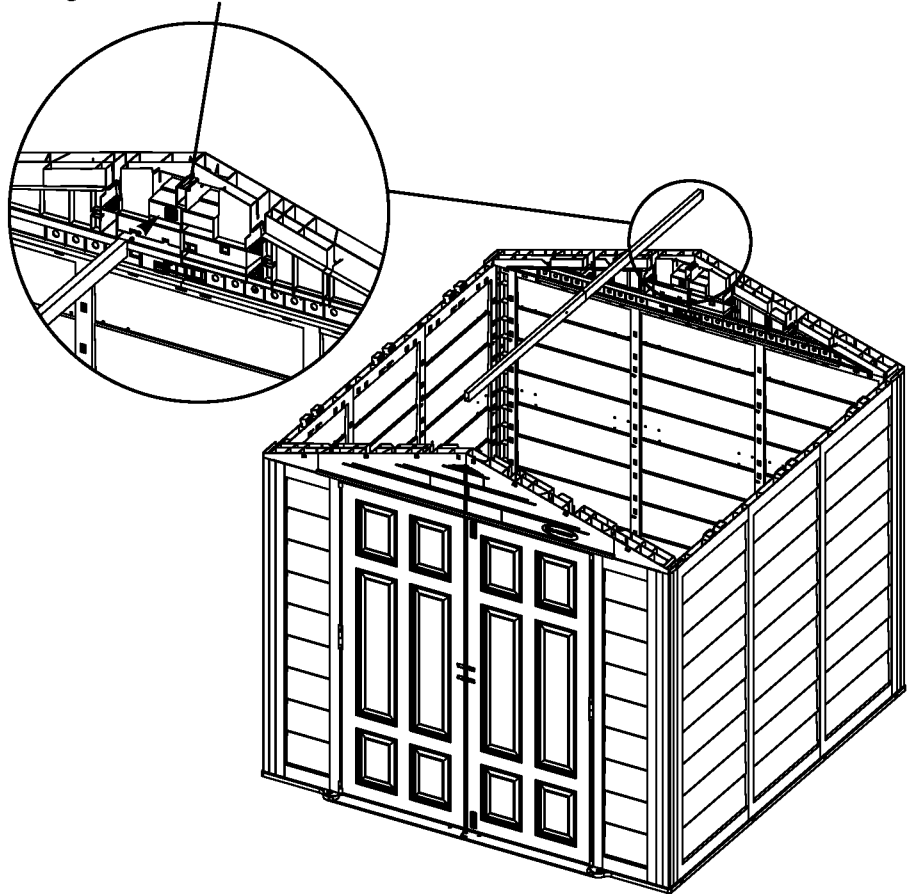

48. Align Female Ridge End K with male end of Mid Ridge V and snap together. Align female end of Mid Ridge V with male end of next Mid Ridge V and snap together.

The number of Mid Ridges depends on the size shed you have purchased. Repeat Mid Ridge to Mid Ridge process for your shed size. Please look at the chart to verify you have the correct number.

Shed size	Number of Mid Ridge V
7 1/2' x 7 1/2'	2
7 1/2' x 10'	3

Align the female end of the last Mid Ridge V with the Male Ridge End C and snap together.

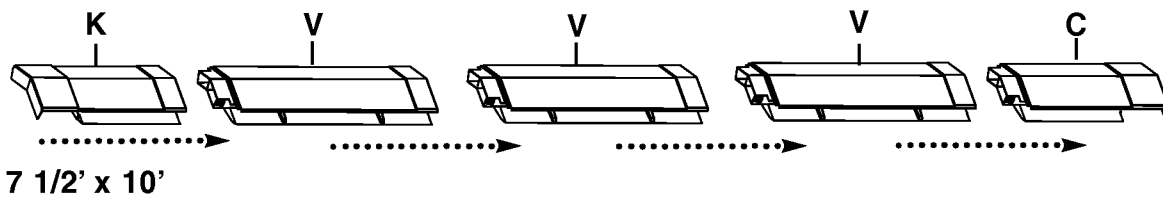
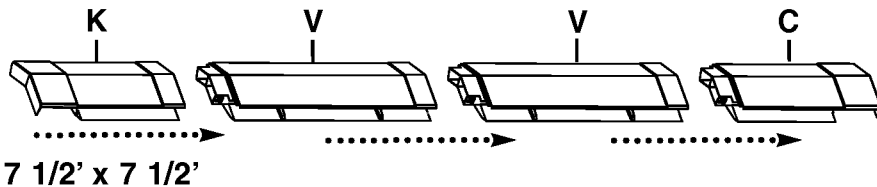

Once Beam is in place **DO NOT** push outward on either header, as Beam may fall.

DO NOT stand beneath Beam until Assembled Ridge Panels are in place.

49. With at least two people, lift the assembled Ridge Panels over the center Steel Ridge Beam and lower into place. Line up Headers with Ridge Ends and Snap together.

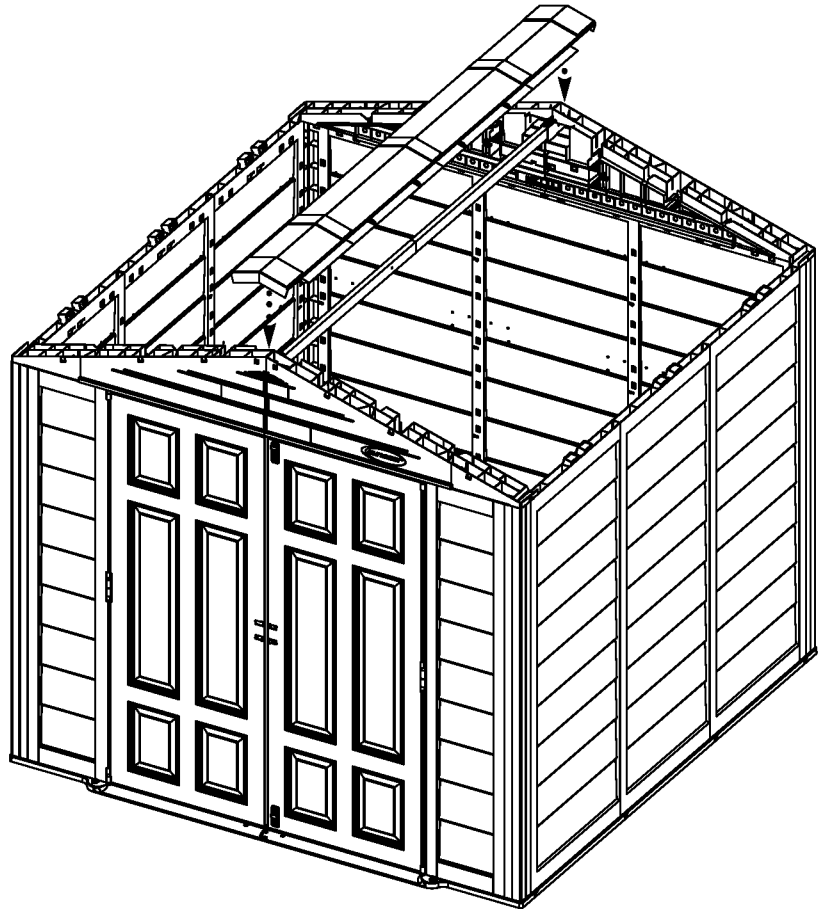

NOTE: Use Caution when handling the Steel Ridge Beams, especially if other people are nearby. The beams are long and if not handled with care can cause damage to persons or property.

50. Standing inside the shed, lower one end of one assembled Steel Ridge Beam into the rectangular pocket at the left of the Back Header.

Still standing inside shed, lower the opposite end of the beam into the pocket in the Front Header.

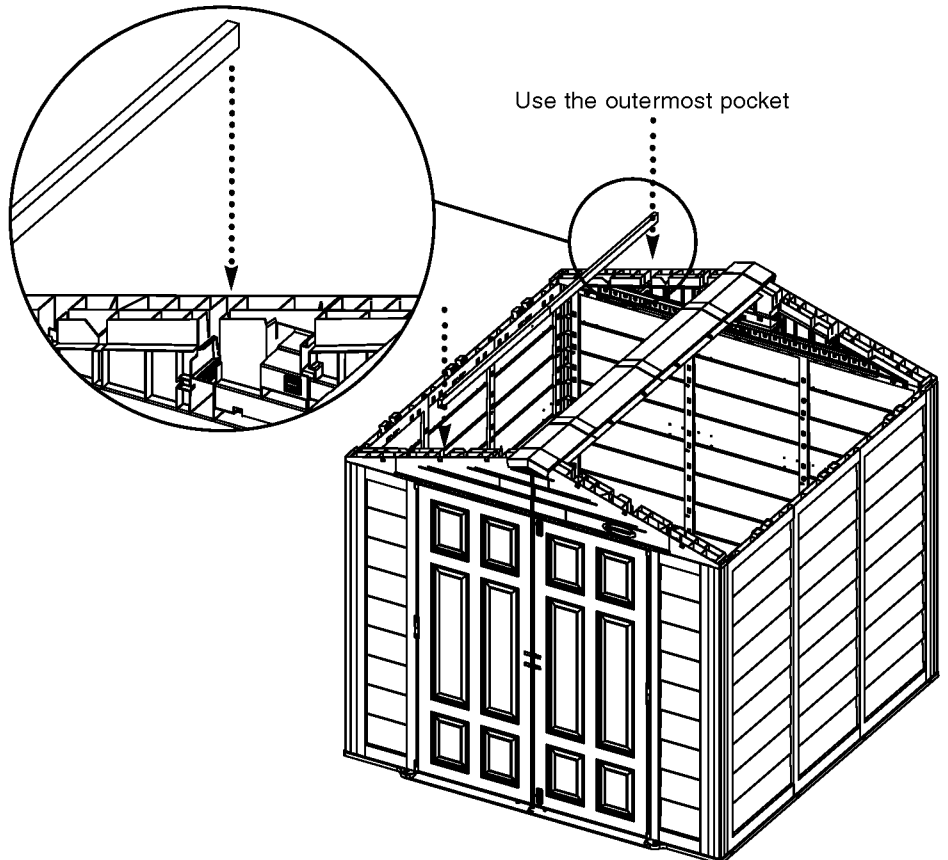

NOTE: Use Caution when handling the Steel Ridge Beams, especially if other people are nearby. The beams are long and if not handled with care can cause damage to persons or property.

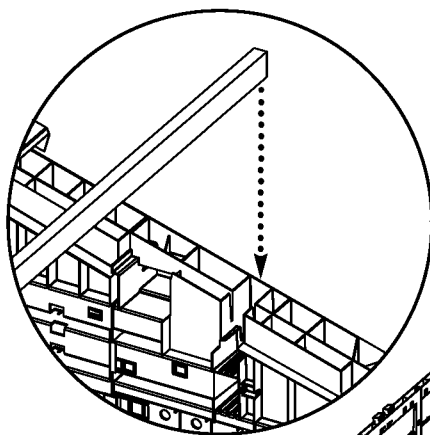

Use the outermost pocket

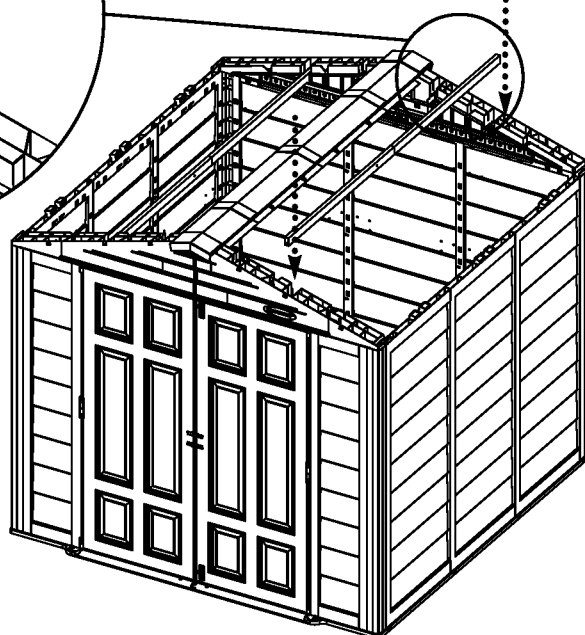

51. Standing inside the shed, lower one end of one assembled Steel Ridge Beam into the rectangular pocket at the right of the Rear Header.

Still standing inside shed, lower the opposite end of the beam into the pocket in the Front Header.

52. Make sure that all Steel Ridge Beams are securely in place.

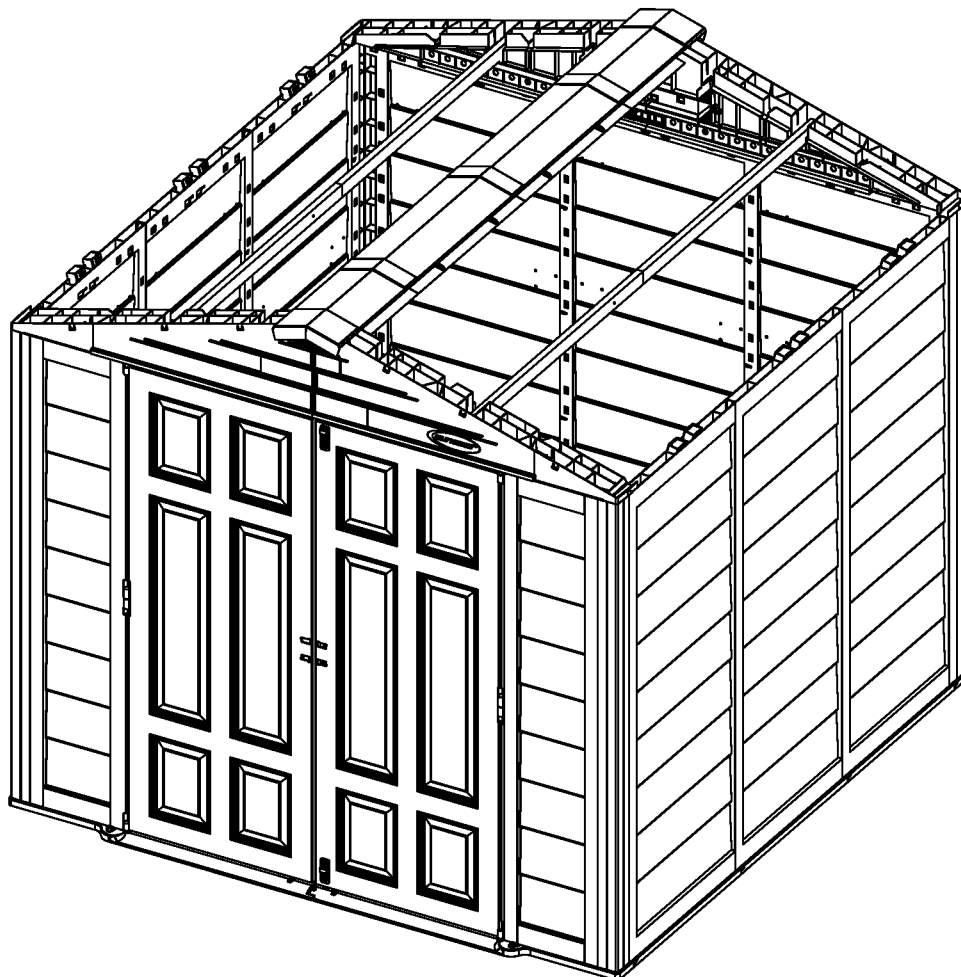

53. Pull pointed end of one Cable Tie through the hole on the small side of Roof to Beam Connector Z.

The number of Roof to Beam Connectors Z used depends on the size of shed being constructed. Please look at the below chart to verify you have the correct number.

Shed size	Number of Roof to Beam Connectors Z
7 1/2' x 7 1/2'	6
7 1/2' x 10'	8

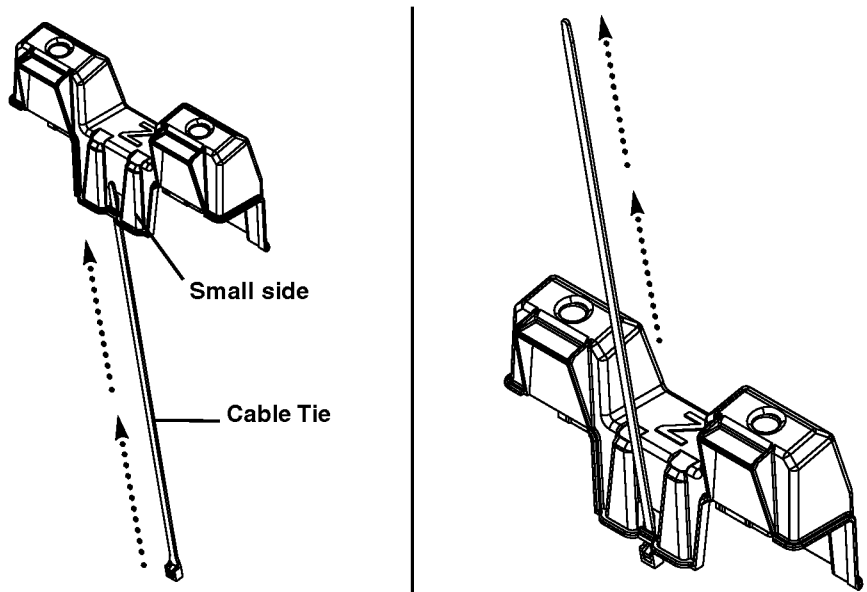

54. Loop Cable Tie over the top of Roof to Beam Connector Z.

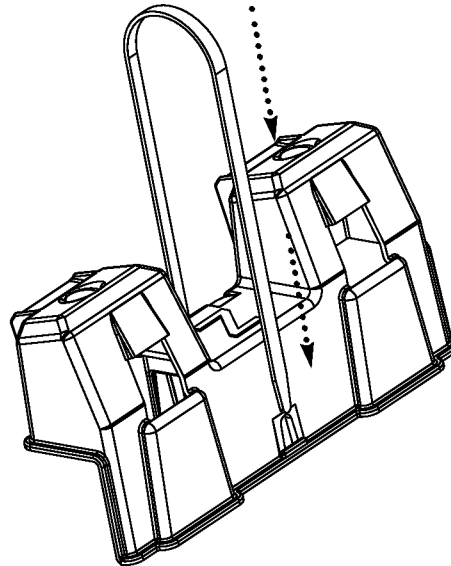

55. Push Cable Tie through remaining hole of Roof to Beam Connector Z.

Repeat for all Roof to Beam Connectors Z.

Set aside for later use.

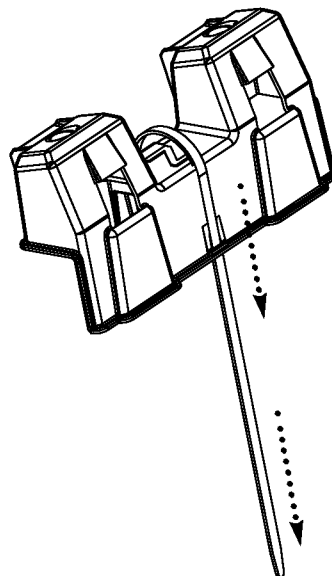

56. With at least two people, start in back left corner of shed and lift one Roof Panel CC-A into position.

Insert left corner of Roof Panel CC-A into the Ridge Assembly making sure that it straddles the Back Header.

Rotate Panel CC-A towards the right and push into Ridge Assembly to snap pieces together.

It may be necessary to have a helper on a step ladder at the back, outside of the shed to help guide the roof panel into the Ridge Assembly. A flat blade screwdriver can be used to open up the Ridge to accept the Roof Panel. Use caution to avoid pinching fingers.

NOTE: Do not engage Roof Panel CC-A to Roof to Side Connector U at this time.

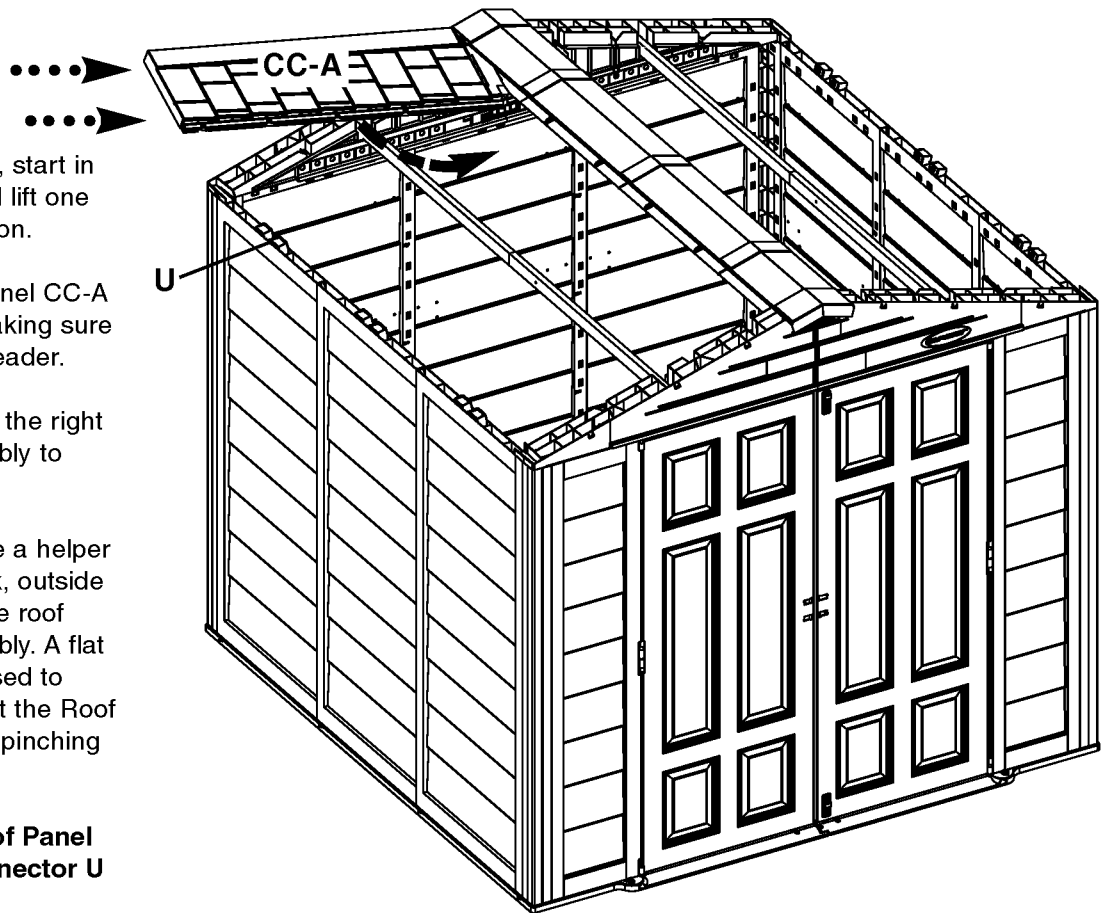

57. Place one Roof to Beam Connector Z with Cable Tie on the Beam as shown.

NOTE: Do not tighten Cable Tie at this point in time.

Lift the roof Panel and slide the Connector halfway underneath.

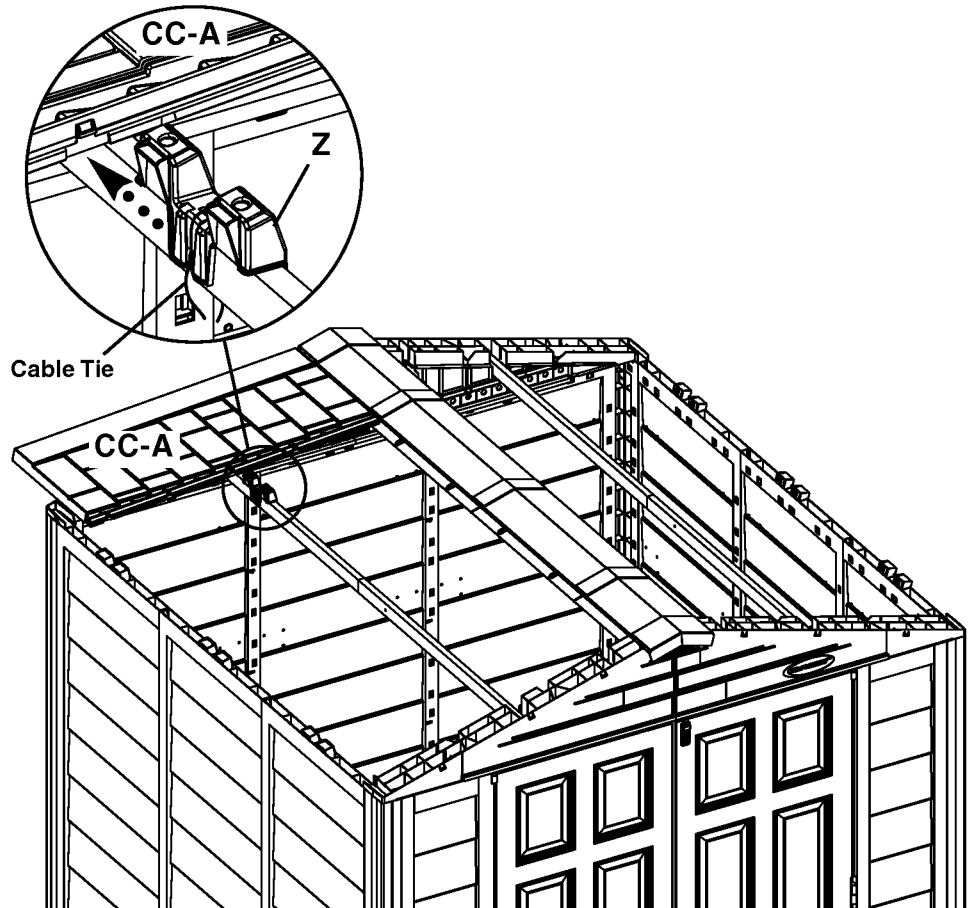

View inside shed looking up

58. Make sure to capture half of Roof to Beam Connector Z in the Roof to Beam Connector Z receptacle in the underside of Roof Panel CC-A.

NOTE: Do not tighten Cable Tie at this point in time.

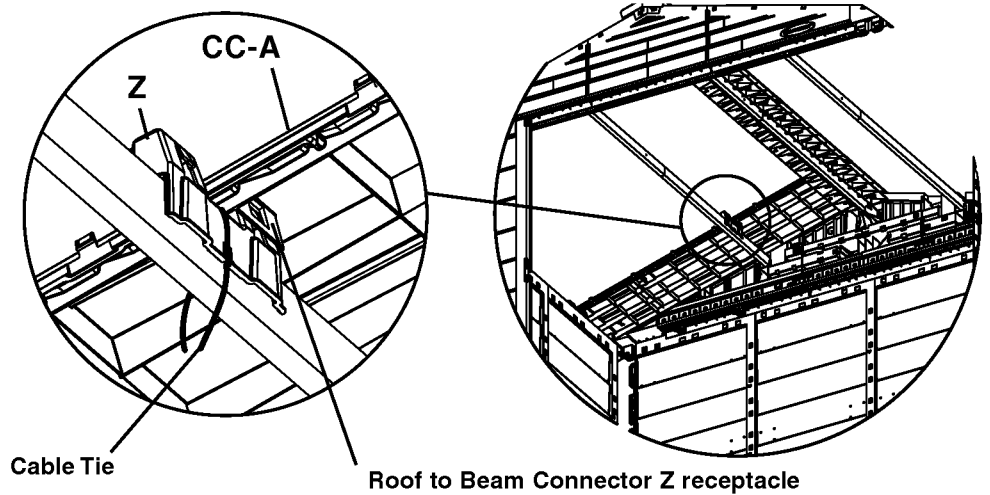

59. Once you have verified that the Ridge Assembly snaps have engaged and that you have captured half the Roof to Beam Connector Z, continue to push the Roof Panel down until Roof to Side Connector U snaps into holes in the underside of the Roof Panel CC-A.

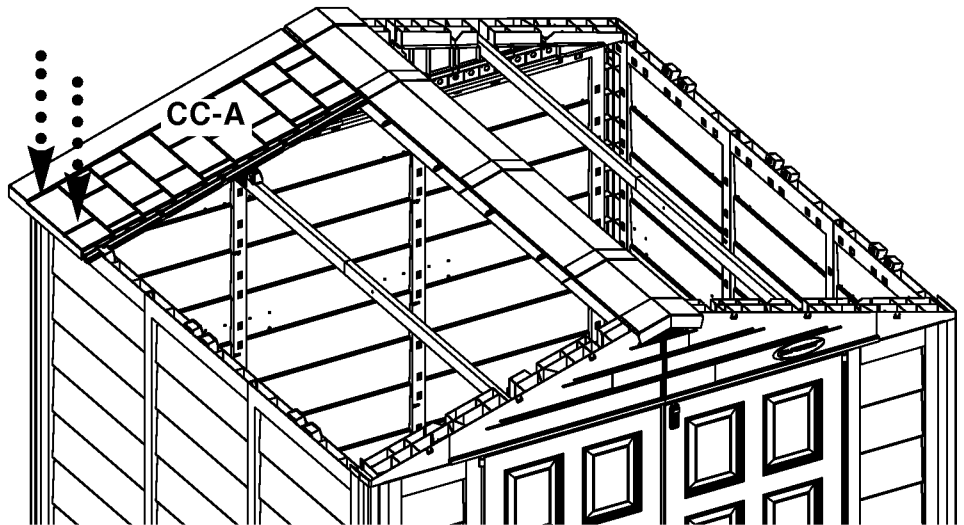

60. With at least two people, lift one Mid Roof Panel J-A into position. Insert right corner of Mid Roof Panel J-A into Ridge Assembly. Rotate Panel towards the left and push straight into Ridge Assembly to snap pieces together.

NOTE: Do not engage Mid Roof Panel J-A to Roof to Side Connector U or Roof to Beam Connector Z at this time.

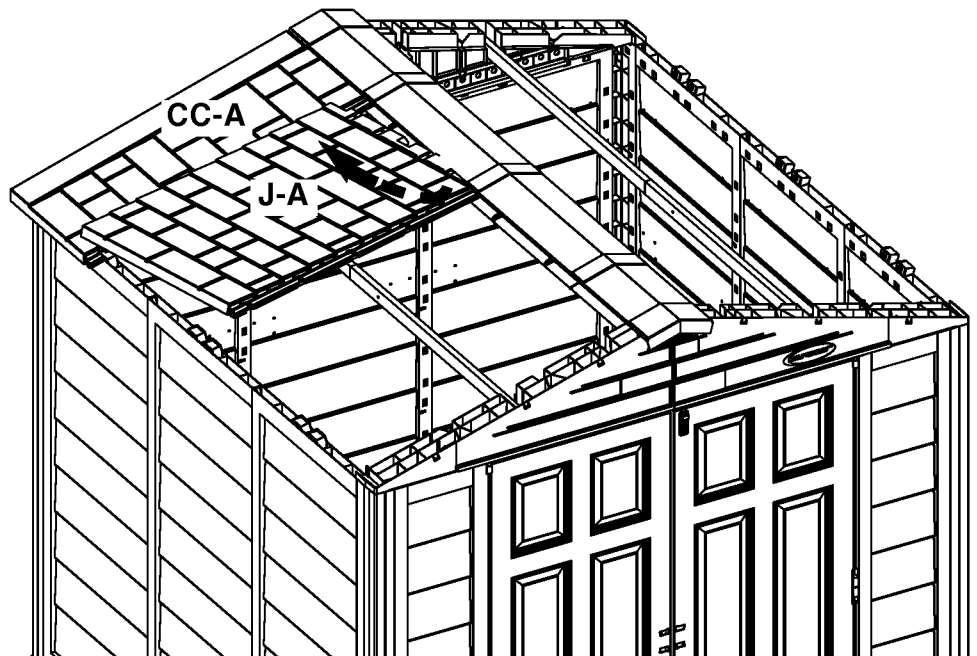

61. While still holding Mid Roof Panel J-A, place a second Roof to Beam Connector Z with Cable Tie on the Beam. Align the second Roof to Beam Connector Z with the receptacle in J-A.

Push roof Panel down to engage First Z Connector and half of the second Z Connector.

Continue to push panel down to engage the Roof to Side Connector U.

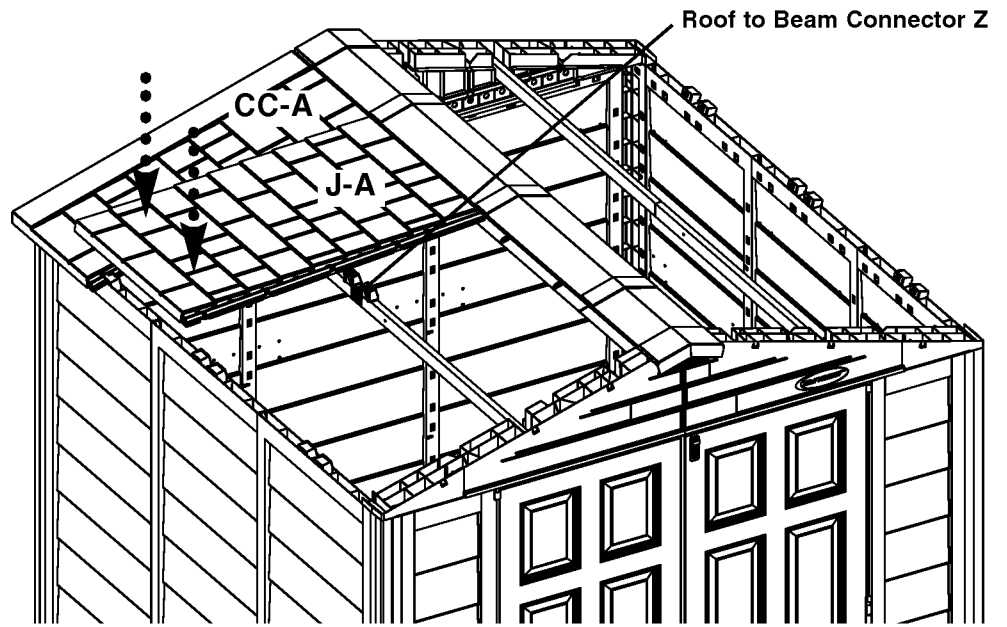

View inside shed looking up

62. From inside the shed, locate the Roof Panel to Roof Panel Snaps and verify that they are fully engaged by queezing them together with your fingers.

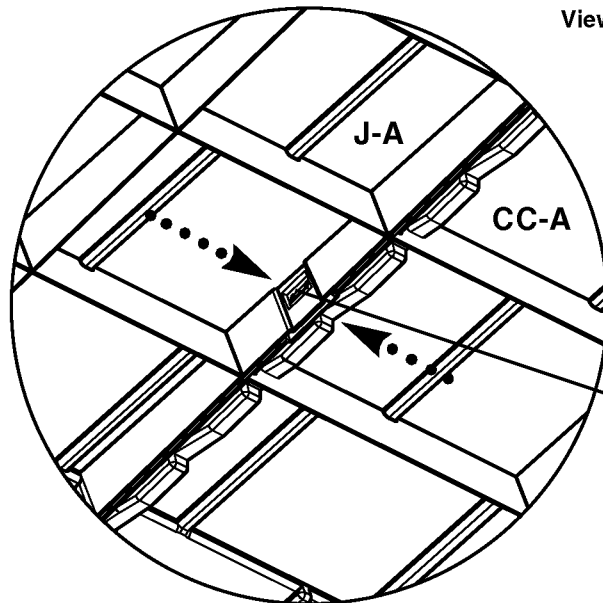

Squeeze Roof Panel to Roof Panel Snap together to fully engage.

63. Repeat process for second Mid Roof Panel J-A.

The number of Mid Roof Panels J-A used depends on the size of shed being constructed. Please look at the below chart to verify you have the correct number.

Shed size	Number of Mid Roof Panels J-A
7 1/2' x 7 1/2'	4
7 1/2' x 10'	6

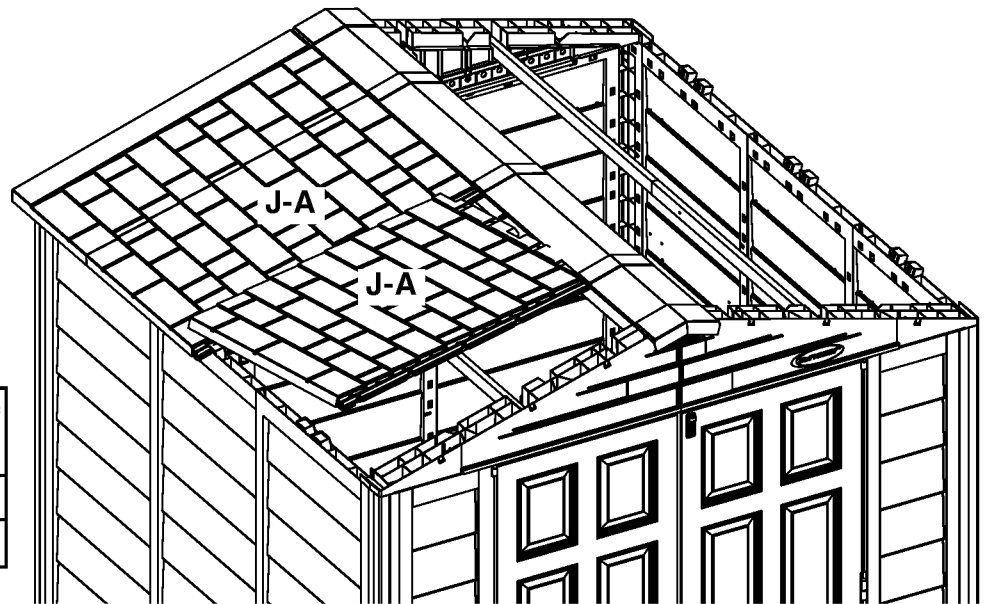

64. Repeat process for Roof Panel X-A.

It may be necessary to have a helper on a step ladder at the front of the shed to help guide the roof panel into the Ridge Assembly. A flat blade screwdriver can be used to open up the Ridge to accept the Roof Panel. Use caution to avoid pinching fingers.

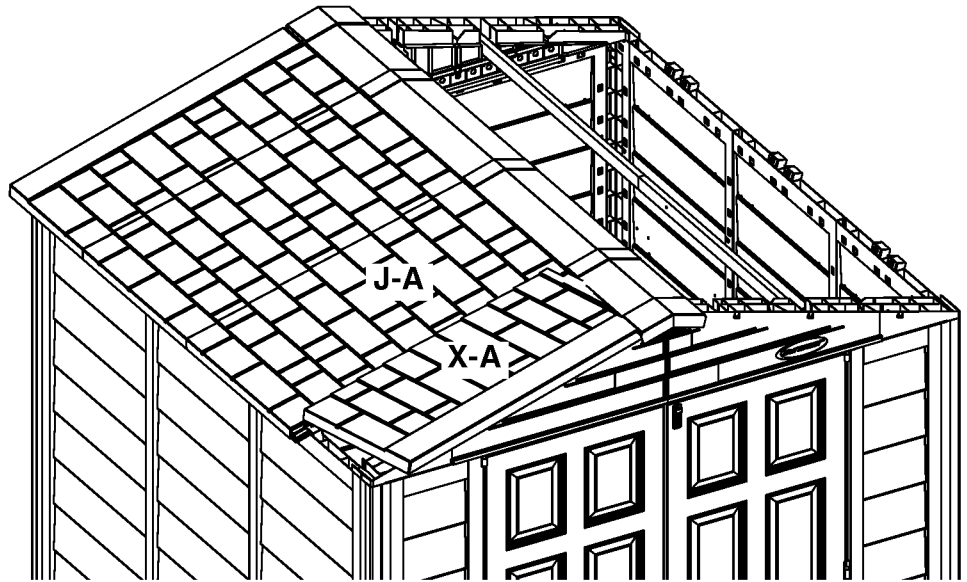

65. Make sure that all Roof Panels and Connectors on left side are securely in place.

Check all connection points and snaps to verify they are fully engaged.

Beginning at the right front corner and working toward the back of the shed, repeat process for right side of shed.

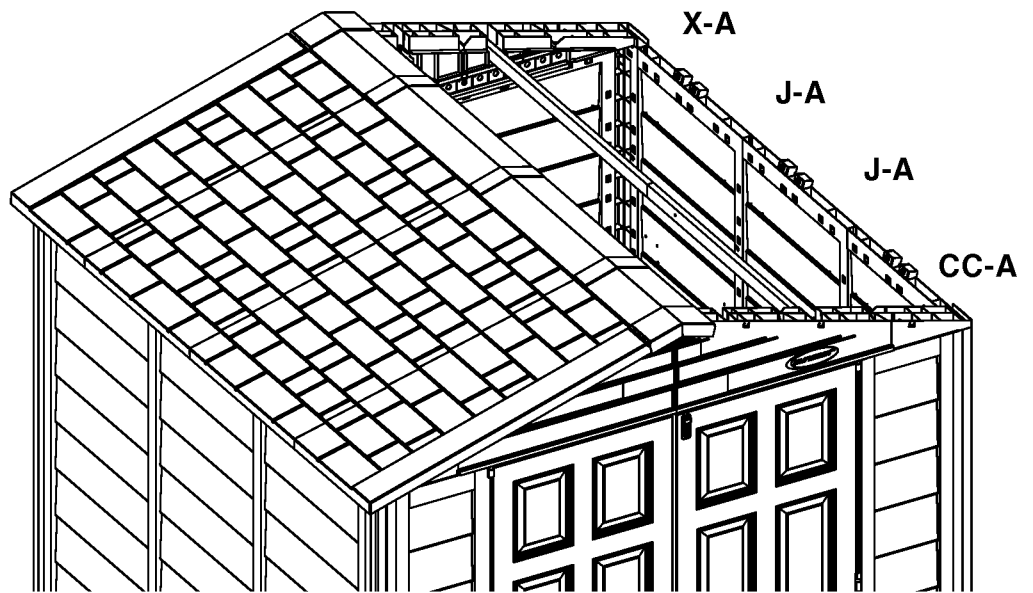

66. From inside the shed insert the male Cable Tie end into the other end and pull until tight.

Once pulled tight, trim the excess Cable tie.

Repeat for all Cable Ties.

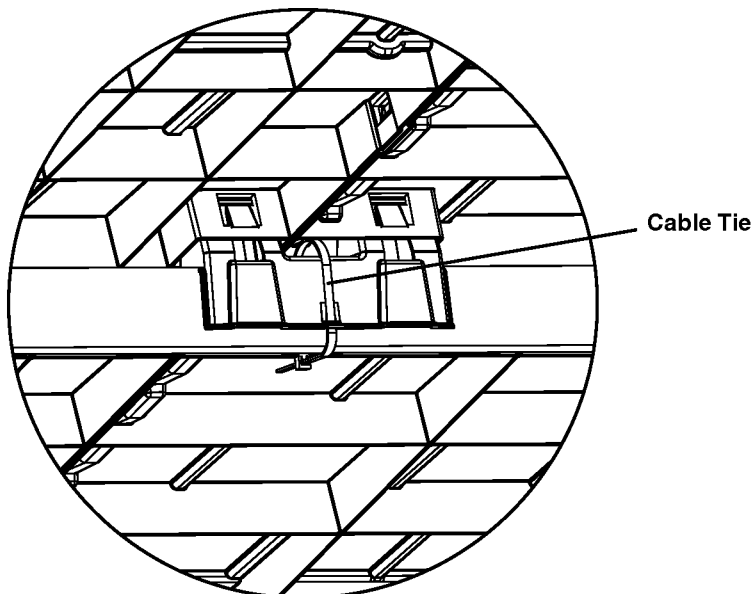

View inside shed looking up

67. Make sure that all Roof Panels and Connectors are securely in place.

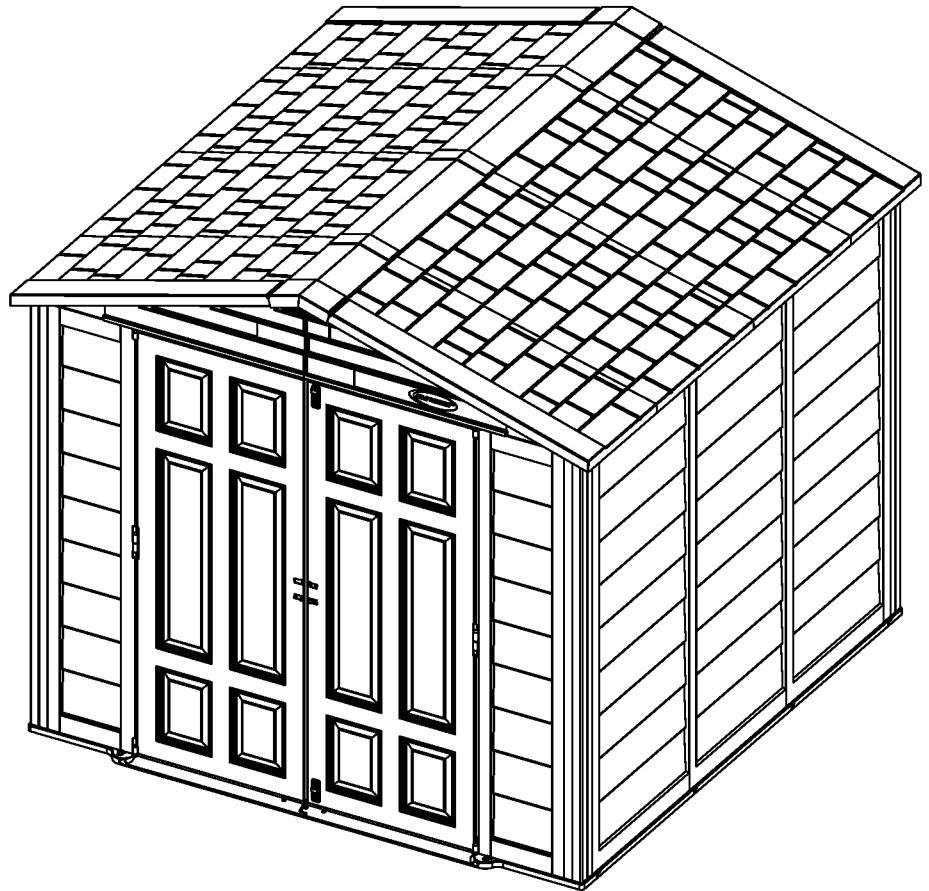

68. Align Left Door Handle W with corresponding holes in Left Door DL and insert.

Secure from back side of Left Door with provided #8-10 x 3/4" Pan Head screws.

TIGHTEN SCREWS WITH A HAND SCREWDRIVER. DO NOT OVERTIGHTEN SCREWS.

Repeat process for Right Door Handle T and Right Door DR.

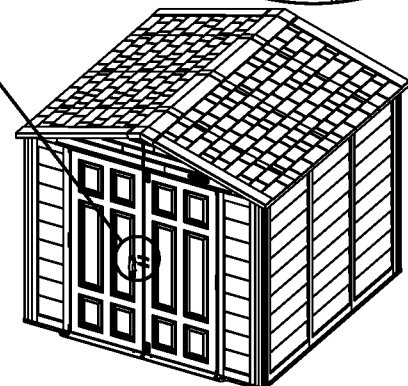
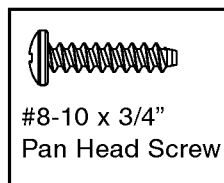
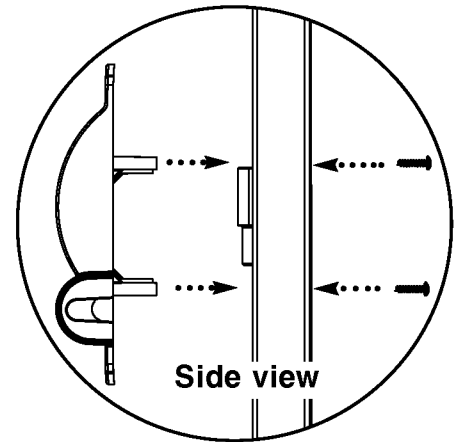
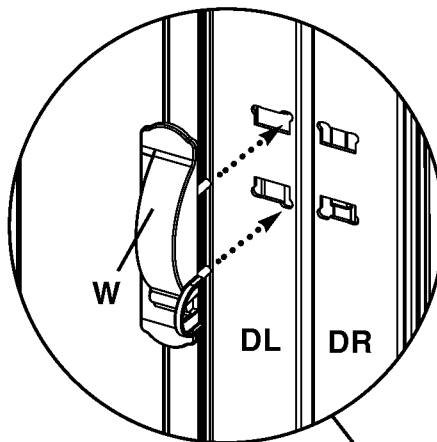

69. Make sure that all parts are securely in place.

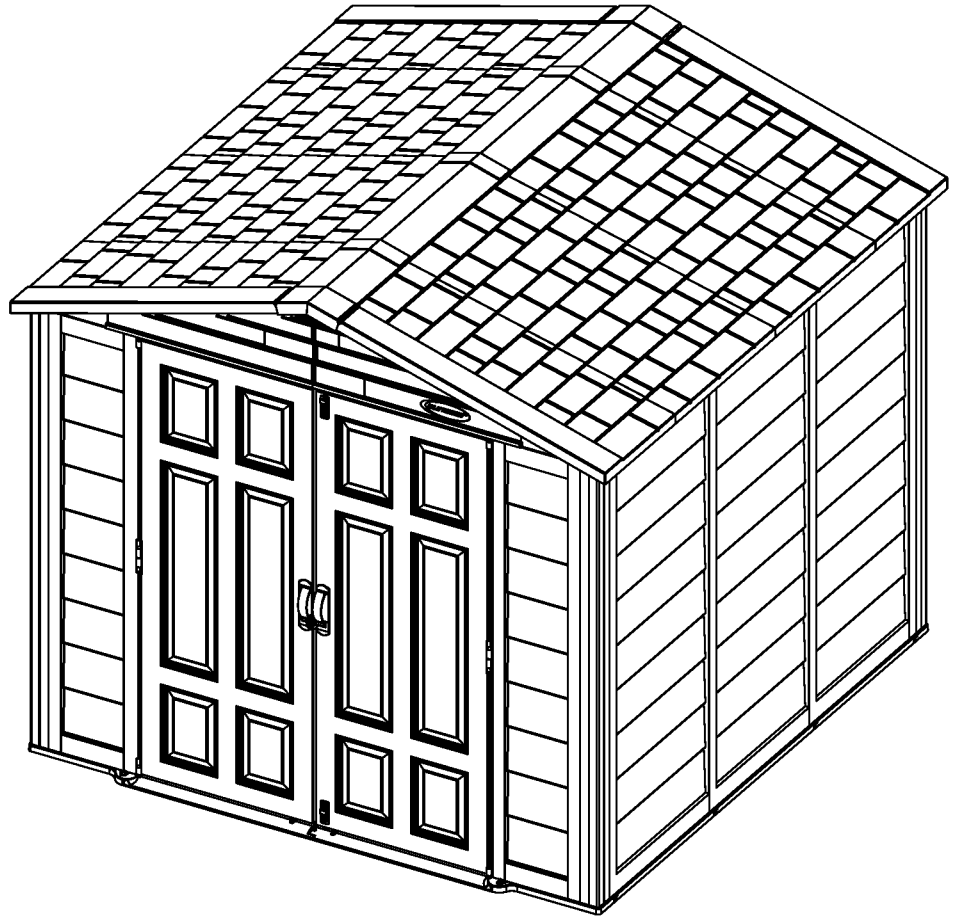

NOTE: Use Caution when handling the Side Panel Supports, especially if other people are nearby. The Supports are long and if not handled with care can cause damage to persons or property.

The number of Side Panel Supports used depends on the size of shed being constructed. Please look at the chart to verify you have the correct number.

Shed size	Number of Side Panel Supports
7 1/2' x 7 1/2'	6
7 1/2' x 10'	8

NOTE: Side Panel Supports are installed where one Side Panel S attaches to another Side Panel S. **Side Panel Supports cannot be used where a Side Panel and Corner Post Assembly meet.**

70. Align hooks on back side of Side Panel Support with receptacles in connection seam of two Side Panels S.

Insert hooks into receptacles, making sure that the hooks pass through **both** Side Panels and slide down to set in place.

A small rubber mallet may be useful to tap the top of the Side Panel Support and ensure correct installation.

Side Panel Support installation

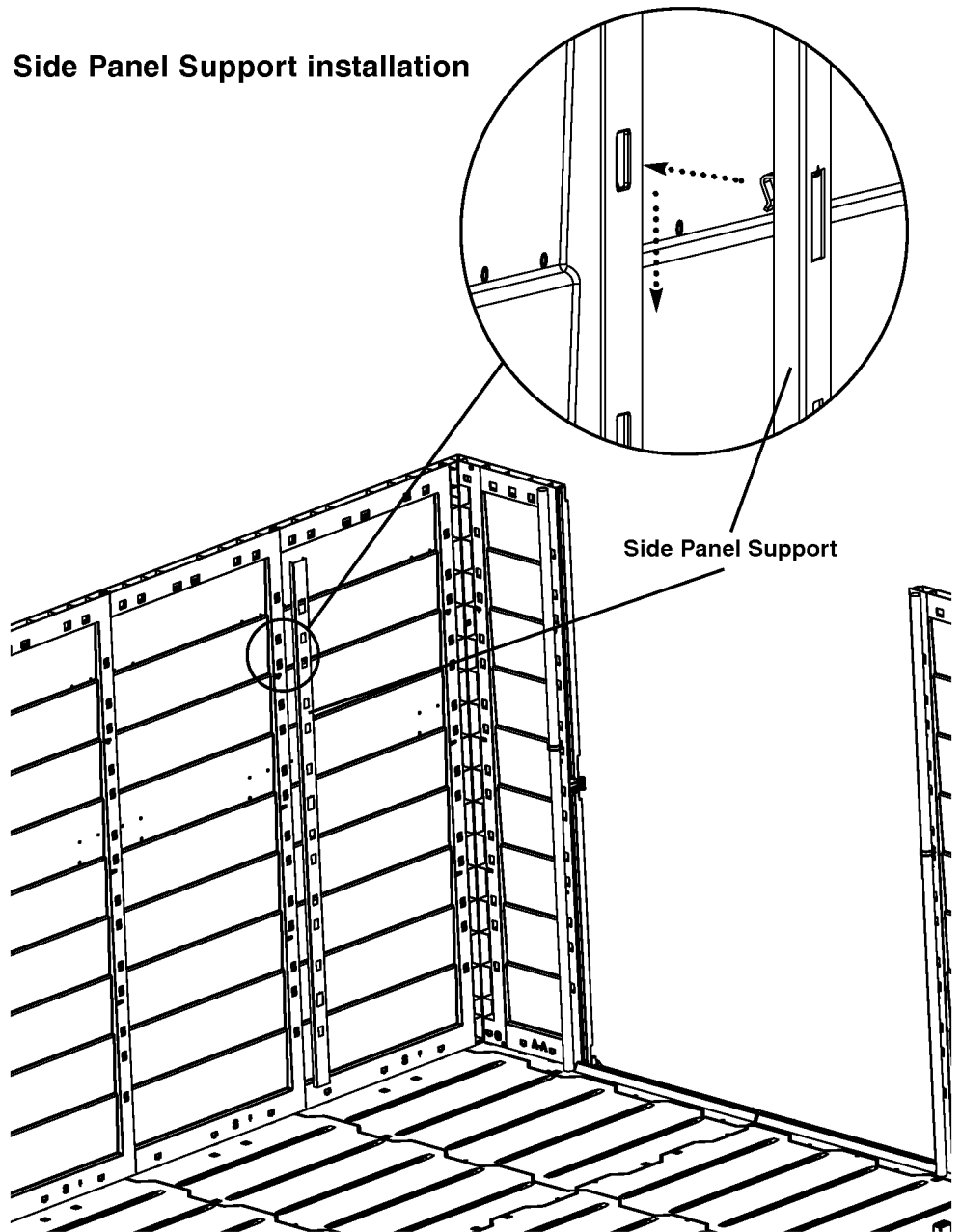

View from inside shed - roof and doors not shown

Accessories Installation

NOTE: ACCESSORIES ARE NOT INCLUDED IN EVERY SHED MODEL.

If your shed has Shutters, but not Window Boxes, follow only Steps 2 and 6.

Window Box and Shutter Installation for Sheds with Windows

1. From inside the shed, align the hooks on the front of Window Box Bracket Assembly with receptacles in Side Panel Supports on either side of window.

Insert hooks into receptacles, making sure that the hooks pass through Side Panel Supports and both Side Panels, and slide down to set in place. A small rubber mallet may be useful to install the Side Panel Support.

The Bracket should fit snugly to the Side Supports.

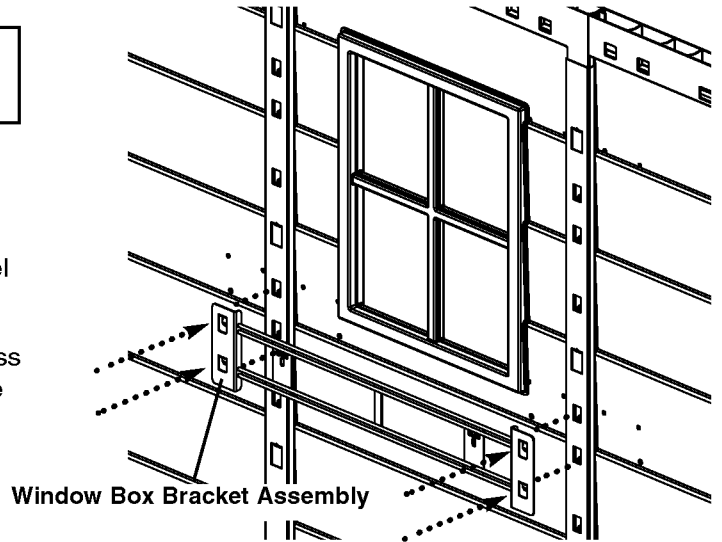

With 3/16" drill bit drill holes for Shutters in these locations

2. From inside the shed, use a 3/16" drill bit and drill holes through the side panels as indicated.

These holes are used to attach Shutters to shed.

NOTE: Drill a straight and level hole through the Side Panels.

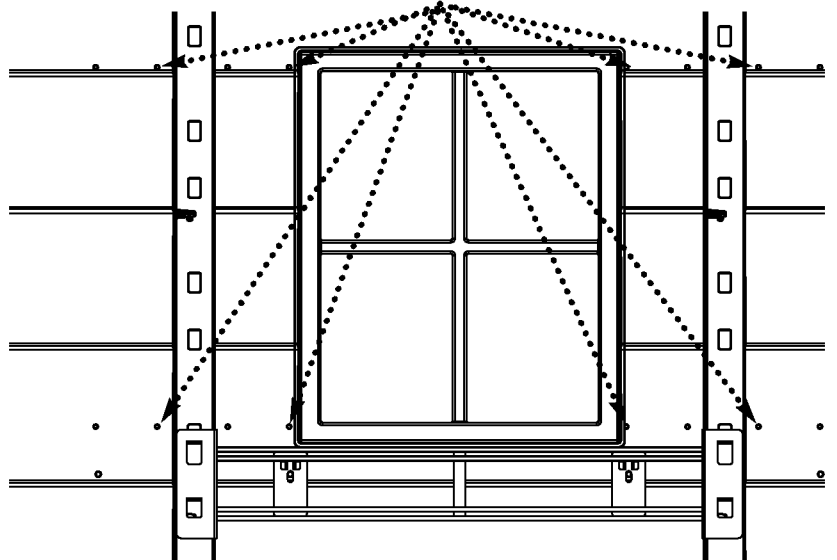

3. From inside the shed and using the Window Box Bracket Assembly as a guide, use a 1/4" drill bit and drill holes through the side panels as indicated.

These holes are used for the Window Box Support Hooks.

NOTE: Drill a straight and level hole through the Side Panels.

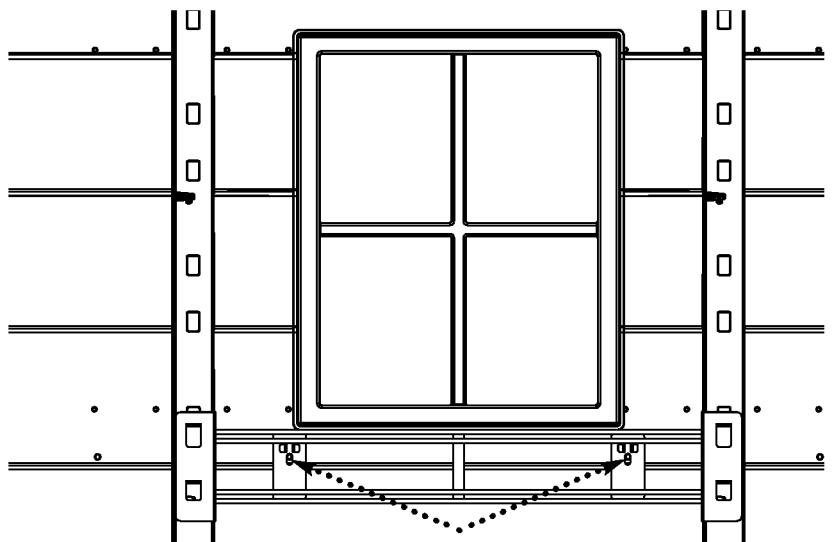

With 1/4" drill bit drill holes for Flower Box Support Hooks in these locations

4. From outside the shed, tilt Window Box Support Hook upward, so it is parallel with window and insert into 1/4" hole. Once inserted rotate Hook downward while guiding through hole.

Repeat for other Window Box Support Hook.

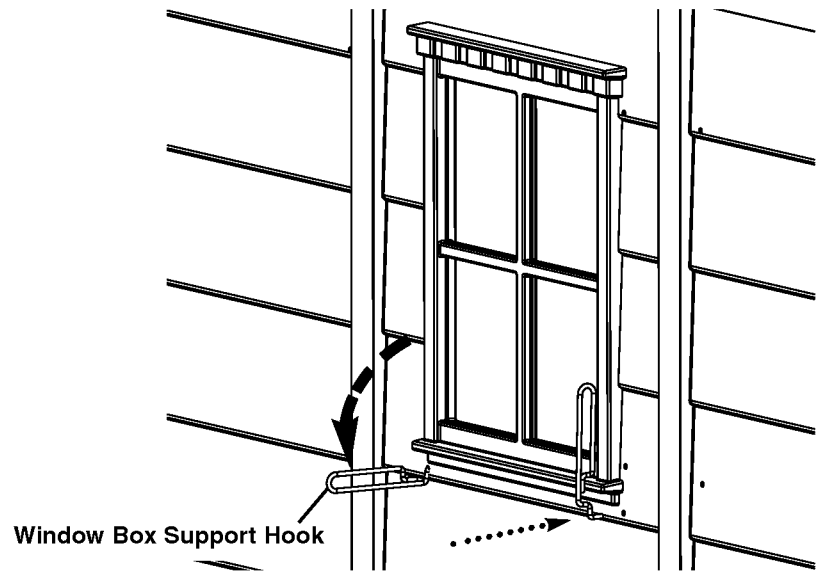

5. From inside shed, make sure the Window Box Support Hook has passed through the Side Panels and Window Box Bracket Assembly.

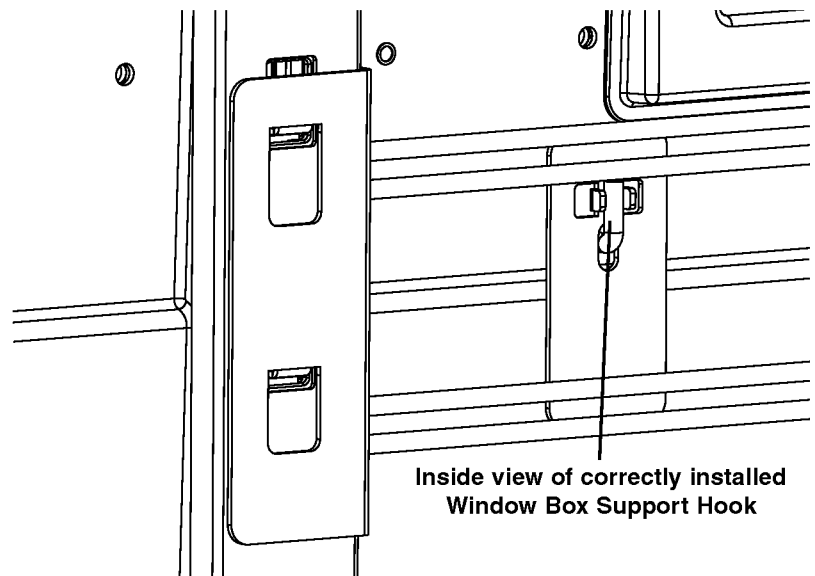

6. Align left Shutter SSL with 3/16" holes on left side of window.

Have one person hold shutter in place against Side Panel. From the inside of shed have second person secure Shutter with provided #8-10 x 3/4" Pan Head screws.

TIGHTEN SCREWS WITH A HAND SCREW-DRIVER. DO NOT OVERTIGHTEN SCREWS.

Repeat process for Right Shutter SSR.

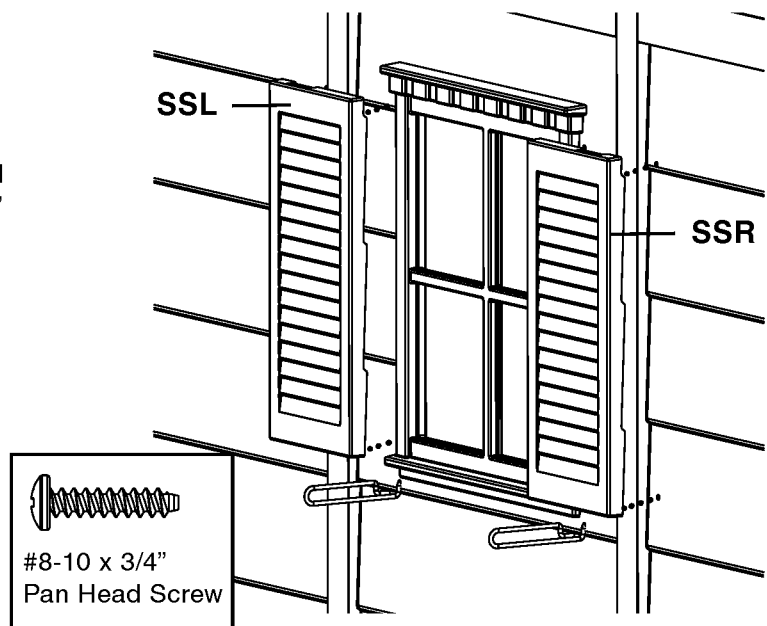

7. Tilt front of Window Box up and guide back edge until it makes contact with Side Panel. Rotate front of Window Box downwards so that Window Box Support Hooks are captured within the channels on each side of Window Box.

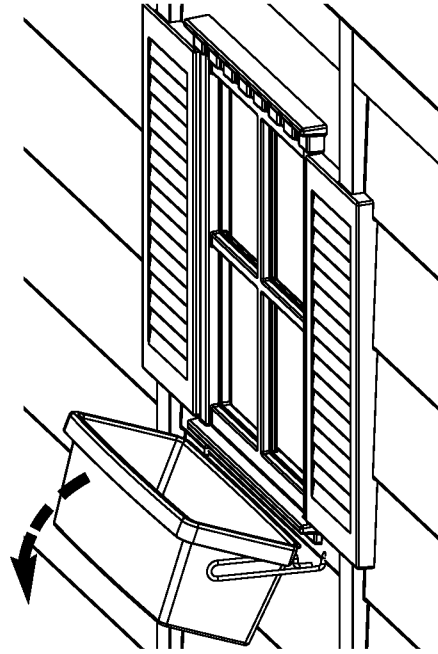

NOTES:

Warranty

Suncast® Corporation, 701 North Kirk Road, Batavia, Illinois 60510 (Manufacturer) warrants to the original purchaser only that the enclosed product is free from material and workmanship defects under normal, household use at time of purchase. Defective product or part must be returned, freight pre-paid, to the Manufacturer's address (Attention: Parts Department) along with proof of purchase. Upon receipt of the aforesaid, the defective product or part will be repaired or replaced at the option of the Manufacturer without charge to the original purchaser and returned to the customer freight collect.

This limited warranty does not apply to damage resulting from accident, neglect, misuse, commercial use, alteration, operation not in accordance with instruction or repairs made or attempted by unauthorized persons.

This limited warranty applies only to the product enclosed and does not apply to accessory parts.

THE MANUFACTURER'S LIABILITY HEREUNDER IS LIMITED SOLELY TO THE REPAIR OR REPLACEMENT OF THE DEFECTIVE PRODUCT OR PART AND THE MANUFACTURER SHALL IN NO EVENT BE LIABLE FOR ANY INCIDENTAL OR CONSEQUENTIAL DAMAGES WHICH MAY RESULT FROM ANY DEFECT IN MATERIAL OR WORKMANSHIP OR FROM THE BREACH OF ANY EXPRESS OR IMPLIED WARRANTY.

Some states do not allow the exclusion or limitation of incidental or consequential damages, or a limitation of how long an implied warranty lasts, so the above limitations may not apply to you. This warranty gives you specific legal rights, and you may have other rights which may vary from state to state.

Factory Repairs

Repair service and assembly assistance are available direct from the factory, not from the place of purchase. If this product requires repair, please call or write us. Warranty repair parts are sent out free of charge. If the product is out of warranty, we will inform you of the charges prior to sending out the parts. VISA and MasterCard are accepted on phone orders. For Assembly or Replacement Parts Information:

Replacement Parts
Suncast Corporation
701 North Kirk Road
Batavia, IL 60510

Outside Illinois, but within North America
800-846-2345
24 hour service / 7 days a week

Within Illinois, or outside North America
630-879-2050
visit: www.suncast.com
email: parts@suncast.com

PATENTS

Patents pending.

Securing Your Shed

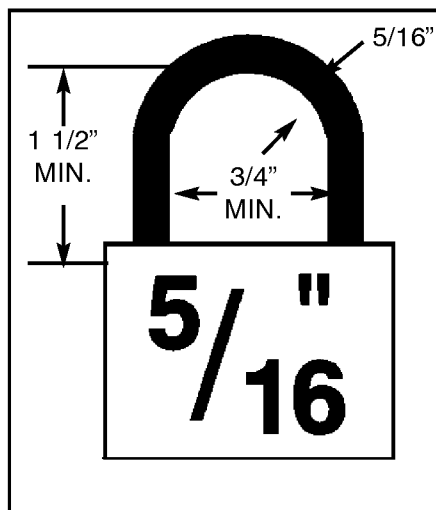

To properly lock your shed using the Padlock Assembly feature, 5/16" padlock is recommended.

Quality Control Number